

# The Harman Kardon Model TD302

Manual 104A

## ULTRAWIDEBAND LINEAR PHASE CASSETTE DECK

# Technical Manual

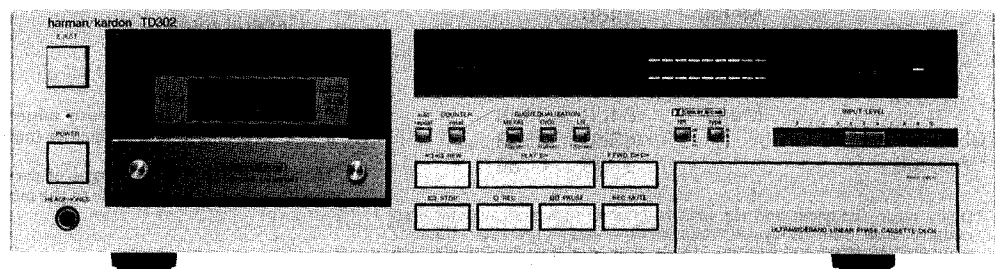

TD302

**harman/kardon**

240 Crossways Park West, Woodbury, N.Y. 11797  
1112-3152104A8 P-088606 1850 Printed in Japan

**SPECIFICATIONS**

Track Configuration 4-track 2 Channel Stereo  
Cassette Deck

**MECHANICAL SECTION**

Record/Playback Tape Speed  
Deviation 4.75 cm/sec. 0.05% ± 1.5%  
Drift 4.75 cm/sec. 0.2% ± 1.5%  
Wow and Flutter 0.05% (NAB) ≤ 0.08%  
0.08% (CCIR) ≤ 0.14%  
Take Up Torque 50gr. cm 35~70gr. cm  
Back Tension 4gr. cm 2~6gr. cm  
F. FWD Torque 100gr. cm 70~150gr. cm  
REW Torque 100gr. cm 70~150gr. cm  
F. FWD/REW Time (C-60 Tape) 90 sec. ≤ 100 sec.  
Motor Direct Drive motor

**AMPLIFIER SECTION**

Bias Frequency 105kHz ± 5kHz  
Playback Output 520mV ± 1.5dB  
Signal-to-Noise Ratio at Line Input (Input 1kHz, 100mV)  
IHF-A WTD at Dolby Level  
Dolby\* NR Off  
LN 51dB  
CrO<sub>2</sub> 54dB  
Metal 54dB  
Dolby NR On  
LN 61dB  
CrO<sub>2</sub> 64dB ≥ 60dB  
Metal 64dB ≥ 60dB  
Channel Separation 45dB ≥ 35dB  
Crosstalk 70dB ≥ 60dB

\*Dolby noise reduction and HX PRO headroom extension manufactured under license from Dolby Laboratories Licensing Corporation. HX PRO originated by Bang and Olufsen. "Dolby", the double-D symbol and "HX PRO" are trademarks of Dolby Laboratories Licensing Corporation.

Record/Playback Distortion (Input 1kHz)  
LN 1.0% ≤ 1.6%  
CrO<sub>2</sub> 1.8% ≤ 3.0%  
Metal 1.0% ≤ 1.6%  
MPX Filter Attenuation  
at 15kHz 0.3dB ≤ 1dB  
at 19kHz 35dB ≥ 30dB  
Erase Ratio (Input 80Hz)  
LN 70dB ≥ 60dB  
Metal 60dB ≥ 56dB  
Input Sensitivity (Input 1kHz) at Line Input 30mV 20(min)~70(max)mV  
Input Impedance (Input 1kHz) at Line Input 23kΩ 19(min)~30(max)kΩ  
**DIMENSIONS (W × H × D)** 17-7/16" × 4-13/16" × 13-1/8"  
(443 × 122 × 334 mm)  
**WEIGHT** 12lbs. 9oz. (5.7kg)  
**POWER SUPPLY**  
U.S.A. model AC 120V, 60Hz  
General model AC 220/240V, 50/60Hz  
**POWER CONSUMPTION**  
U.S.A. model 20W  
General model 22W

Specifications and components subject to change without notice. Overall performance will be maintained or improved.

This specification is the target of servicing. But, there is a case that the specification is not applicable to the measurement condition and instrument.

**LEAKAGE TEST (FOR SERVICE ENGINEERS IN THE U.S.A.)**

Before returning the unit to the user, perform the following safety checks:

1. Inspect all lead dress to make certain that leads are not pinched or that hardware is not lodged between the chassis and other metal parts in the unit.
2. Be sure that any protective devices such as nonmetallic control knobs, insulating fishpapers, cabinet backs, adjustment and compartment cover or shields, isolation resistor-capacity networks, mechanical insulators, etc. which were removed for servicing are properly reinstalled.
3. Be sure that no shock hazard exists; check for leakage current using Simpson Model 229 Leakage Tester, standard equipment item No. 21641, RCA Model WT540A or use alternate method as follows:  
Plug the power cord directly into a 120-volt AC receptacle (do not use an Isolation Transformer for this test). Using two clip leads, connect a 1500 Ohm, 10-watt resistor paralleled by a 0.15 μF capacitor, in series with all exposed metal cabinet parts and a known earth ground, such as a water pipe or conduit. Use a VTVM or VOM with 1000 Ohms per volt, or higher, sensitivity to measure the AC voltage drop across the resistor. (See Diagram.) Move the resistor connection to each exposed metal part having a return path to the chassis (antenna, metal, cabinet, screw heads, knobs and control shafts, escutcheon, etc.) and measure the AC voltage drop across the resistor. (This test should be performed with the power switch in both the On and Off positions.)  
A reading of 0.35 volt RMS or more is excessive and indicates a potential shock hazard which must be corrected before returning the unit to the owner.

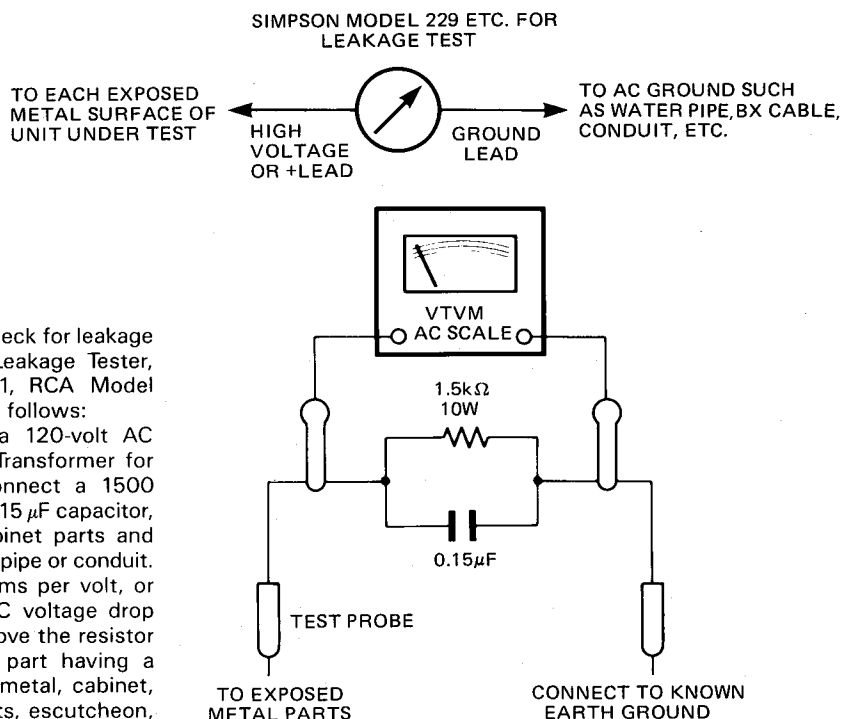

TD302

## CONTROLS AND FUNCTIONS

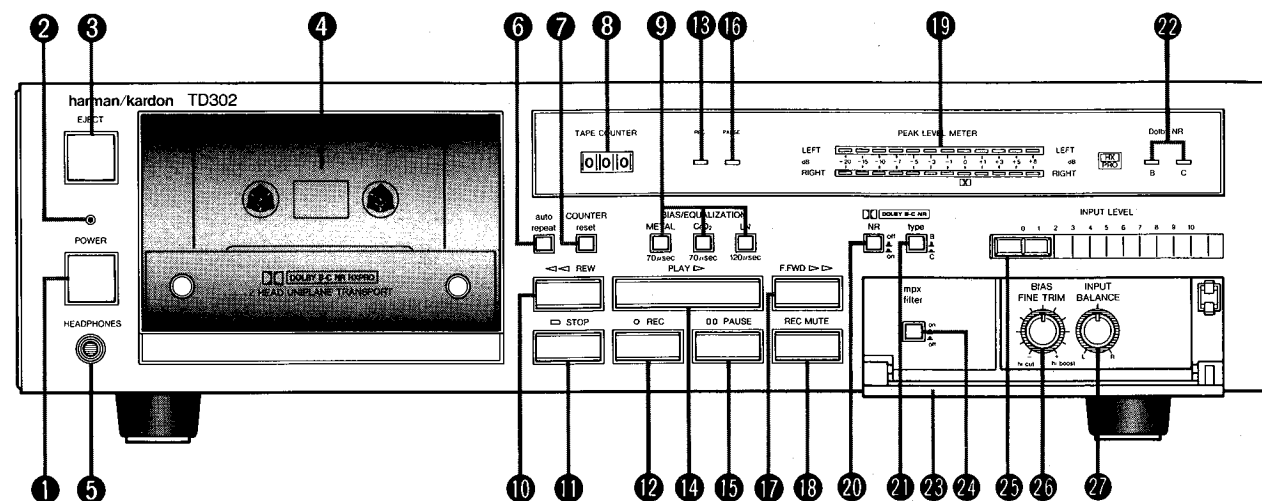
**1 POWER SWITCH (POWER)**

Pressing this switch will turn on the power and the POWER indicator lights up. Press the switch again to turn the power off.

**2 POWER INDICATOR****3 EJECT BUTTON (EJECT)**

The soft eject mechanism opens the door slowly when this button is pressed.

**CAUTION:** This button cannot be depressed while the tape is running. Be sure to press the STOP button before pressing the EJECT button.

**4 CASSETTE COMPARTMENT****5 HEADPHONES JACK (HEADPHONES)**

Stereo headphones with a standard 1/4 inch plug can be connected to this jack. When headphones are connected, the sound during recording or playback can be listened to without connecting this unit to a receiver.

**6 AUTOMATIC REPEAT BUTTON (auto repeat)**

When this button is depressed, the cassette deck will continuously rewind and replay one side of the tape.

**7 COUNTER RESET BUTTON (COUNTER reset)**

Press this button to reset the TAPE COUNTER when starting to record.

**8 TAPE COUNTER**

For a digital indication of the position on a cassette tape. The figure changes as the tape runs. Cueing for the start of a selection is facilitated by making a note of the counter reading.

**9 TAPE SELECTORS (BIAS/EQUALIZATION)**

For selection of the record and playback circuitry that provides the lowest distortion and flattest frequency response for metal, chromium dioxide (CrO<sub>2</sub>) or low noise (LN) tape.

**10 REWIND BUTTON (REW)**

Press this button to rewind a tape at high speed.

**11 STOP BUTTON (STOP)**

Press this button to stop each operation. Pressing this button stops the playback, recording, fast forward and rewind modes. It also cancels the standby mode activated by the PAUSE button.

**12 RECORD BUTTON (REC)**

Press this button and the PAUSE button simultaneously to provide the record standby mode. The RECORD and PAUSE indicators will illuminate. Recording starts when the PLAY button is pressed.

**13 RECORD INDICATOR**

For indication that the tape is being recorded.

**14 PLAY BUTTON (PLAY)**

Press this button to start playback.

**15 PAUSE BUTTON (PAUSE)**

Press this button to temporarily stop playback or recording. This button also activates the record standby mode when pressed simultaneously with the RECORD button.

**16 PAUSE INDICATOR**

For indication that the pause mode has been activated.

**17 FAST FORWARD BUTTON (F.FWD)**

Press this button to quickly advance the tape in the same direction as it is played.

**18 RECORD MUTE BUTTON (REC MUTE)**

This button allows you to create a silent segment of tape at any time while recording. The button is a momentary contact type and will not lock in the depressed position. The record mute feature will only operate while the button is held in the depressed position.

**19 PEAK LEVEL METER**

The level of the signal being recorded or played is displayed clearly on this meter.

**20 DOLBY NR SWITCH (NR)**

Depress this switch for recording or playback using the Dolby NR system. The green DOLBY NR indicator (for B-type) or the amber one (for C-type) illuminates according to the DOLBY NR TYPE selector position. Press the switch again to turn off the Dolby NR system.

**21 DOLBY NR TYPE SELECTOR (type)**

For selection of the Dolby B- or C-type NR system. Depress this switch to select the Dolby C-type NR system. Press it again to select the Dolby B-type system.

**22 DOLBY NR INDICATOR**

For indication that Dolby B or C noise reduction circuitry is activated.

**23 SUB-PANEL DOOR**

Press the upper right part of the SUB-PANEL DOOR and it will release. Then open the door with your hand to access the sub-panel.

**24 MPX FILTER SWITCH (mpx filter)**

The MPX filter is a high frequency filter that has very little effect below 16kHz, but has 30dB attenuation at 19kHz, the frequency of the FM stereo pilot signal. Depress and release this switch (to the "on" position) when recording from an FM stereo tuner or receiver. However, to appreciate the ultrawideband frequency response of the TD302, depress this switch (to the "off" position) when recording all other sources, such as a turntable, tape deck, etc.

**25 INPUT LEVEL CONTROL KNOB (INPUT LEVEL)**

This knob adjusts the record level of the input signal.

**26 BIAS FINE TRIM KNOB (BIAS FINE TRIM)**

For precise adjustment of the bias used during recording.

**27 INPUT BALANCE CONTROL KNOB (INPUT BALANCE)**

This knob is used to restore the input level balance when the levels of the right and left channels are extremely different or to deliberately upset the input level balance as you like. Usually, it is set at the center. Turn it to the clockwise, the recording level of left channel is decreased. Turn it to the counterclockwise, the recording level of right channel is decreased.

## CONTROLS AND FUNCTIONS

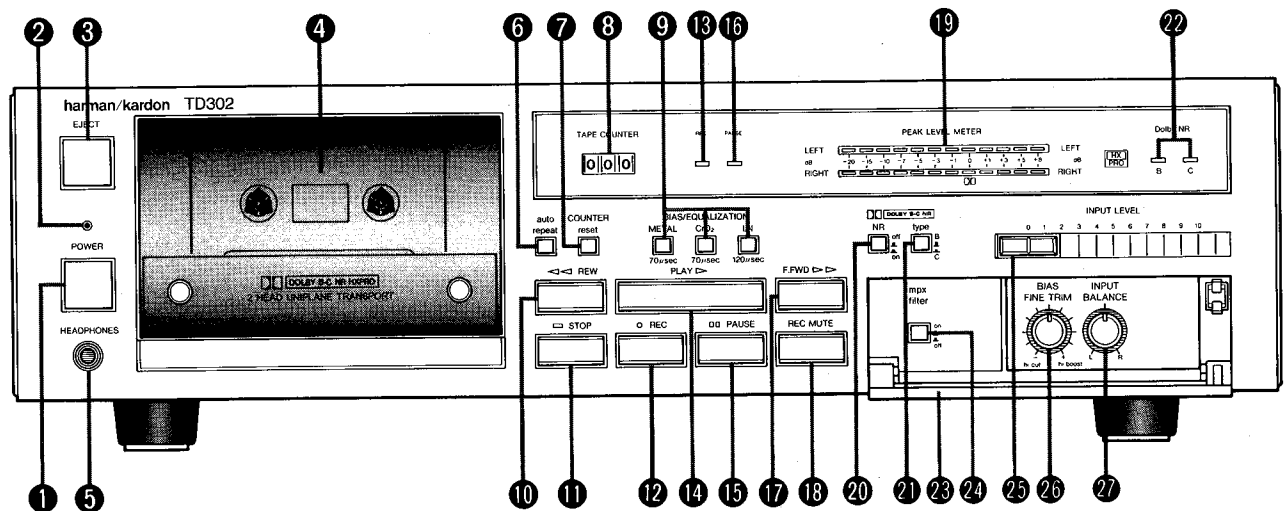

### 1 POWER SWITCH (POWER)

Pressing this switch will turn on the power and the POWER indicator lights up. Press the switch again to turn the power off.

### 2 POWER INDICATOR

### 3 EJECT BUTTON (EJECT)

The soft eject mechanism opens the door slowly when this button is pressed.

**CAUTION:** This button cannot be depressed while the tape is running. Be sure to press the STOP button before pressing the EJECT button.

### 4 CASSETTE COMPARTMENT

### 5 HEADPHONES JACK (HEADPHONES)

Stereo headphones with a standard 1/4 inch plug can be connected to this jack. When headphones are connected, the sound during recording or playback can be listened to without connecting this unit to a receiver.

### 6 AUTOMATIC REPEAT BUTTON (auto repeat)

When this button is depressed, the cassette deck will continuously rewind and replay one side of the tape.

### 7 COUNTER RESET BUTTON (COUNTER reset)

Press this button to reset the TAPE COUNTER when starting to record.

### 8 TAPE COUNTER

For a digital indication of the position on a cassette tape. The figure changes as the tape runs. Cueing for the start of a selection is facilitated by making a note of the counter reading.

### 9 TAPE SELECTORS (BIAS/EQUALIZATION)

For selection of the record and playback circuitry that provides the lowest distortion and flattest frequency response for metal, chromium dioxide (CrO<sub>2</sub>) or low noise (LN) tape.

### 10 REWIND BUTTON (REW)

Press this button to rewind a tape at high speed.

### 11 STOP BUTTON (STOP)

Press this button to stop each operation. Pressing this button stops the playback, recording, fast forward and rewind modes. It also cancels the standby mode activated by the PAUSE button.

**12 RECORD BUTTON (REC)**

Press this button and the PAUSE button simultaneously to provide the record standby mode. The RECORD and PAUSE indicators will illuminate. Recording starts when the PLAY button is pressed.

**13 RECORD INDICATOR**

For indication that the tape is being recorded.

**14 PLAY BUTTON (PLAY)**

Press this button to start playback.

**15 PAUSE BUTTON (PAUSE)**

Press this button to temporarily stop playback or recording. This button also activates the record standby mode when pressed simultaneously with the RECORD button.

**16 PAUSE INDICATOR**

For indication that the pause mode has been activated.

**17 FAST FORWARD BUTTON (F.FWD)**

Press this button to quickly advance the tape in the same direction as it is played.

**18 RECORD MUTE BUTTON (REC MUTE)**

This button allows you to create a silent segment of tape at any time while recording. The button is a momentary contact type and will not lock in the depressed position. The record mute feature will only operate while the button is held in the depressed position.

**19 PEAK LEVEL METER**

The level of the signal being recorded or played is displayed clearly on this meter.

**20 DOLBY NR SWITCH (NR)**

Depress this switch for recording or playback using the Dolby NR system. The green DOLBY NR indicator (for B-type) or the amber one (for C-type) illuminates according to the DOLBY NR TYPE selector position. Press the switch again to turn off the Dolby NR system.

**21 DOLBY NR TYPE SELECTOR (type)**

For selection of the Dolby B- or C-type NR system. Depress this switch to select the Dolby C-type NR system. Press it again to select the Dolby B-type system.

**22 DOLBY NR INDICATOR**

For indication that Dolby B or C noise reduction circuitry is activated.

**23 SUB-PANEL DOOR**

Press the upper right part of the SUB-PANEL DOOR and it will release. Then open the door with your hand to access the sub-panel.

**24 MPX FILTER SWITCH (mpx filter)**

The MPX filter is a high frequency filter that has very little effect below 16kHz, but has 30dB attenuation at 19kHz, the frequency of the FM stereo pilot signal. Depress and release this switch (to the "on" position) when recording from an FM stereo tuner or receiver. However, to appreciate the ultrawideband frequency response of the TD302, depress this switch (to the "off" position) when recording all other sources, such as a turntable, tape deck, etc.

**25 INPUT LEVEL CONTROL KNOB (INPUT LEVEL)**

This knob adjusts the record level of the input signal.

**26 BIAS FINE TRIM KNOB (BIAS FINE TRIM)**

For precise adjustment of the bias used during recording.

**27 INPUT BALANCE CONTROL KNOB (INPUT BALANCE)**

This knob is used to restore the input level balance when the levels of the right and left channels are extremely different or to deliberately upset the input level balance as you like. Usually, it is set at the center. Turn it to the clockwise, the recording level of left channel is decreased. Turn it to the counterclockwise, the recording level of right channel is decreased.

**DISASSEMBLY PROCEDURES (REFER TO PAGES 5 AND 16)**

**① CABINET TOP ASSEMBLY (101) REMOVAL**

Remove 6 screws ④ and then remove the Cabinet Top Assembly (101).

**② FRONT PANEL ASSEMBLY (102) REMOVAL**

1. Remove the Cabinet Top Assembly (101). (Refer to step ①.)
2. Remove 7 screws ③ and then remove the Front Panel Assembly (102).

**③ CASSETTE TAPE RECORDER MECHANISM ASSEMBLY (111) REMOVAL**

1. Remove the Front Panel Assembly (102). (Refer to step ②.)
2. Disconnect the LCN201 connected to the Cassette Tape Recorder Mechanism Assembly (111).
3. From the Record/Playback Head and Erase Head, unsolder the lead wires connected to the Main P. C. Board (PCB-1).
4. Loosen 8 screws ⑥ and then remove the Cabinet Bottom (128).
5. Remove the Belt (211) of the Tape Counter.
6. Remove 4 screws ⑦ and then remove the Cassette Tape Recorder Mechanism Assembly (111).

**④ MAIN P. C. BOARD (PCB-1) REMOVAL**

1. Remove the Cabinet Top Assembly (101). (Refer to step ①.)

2. Disconnect the LCN201 and LCN202 connected to the Cassette Tape Recorder Mechanism Assembly (111) and Peak Level Meter (D401).
3. Open the lid of connectors (CN103 ~ CN108, CN110, CN301 and CN302) on the Main P. C. Board (PCB-1) and disconnect the lead wires.
4. Unsolder the lead wires connected to the Main P. C. Board (PCB-1).
5. Remove 7 screws ③ and then remove the Main P. C. Board (PCB-1).

**⑤ OTHER P. C. BOARDS REMOVAL**

1. Remove the Front Panel Assembly (102). (Refer to step ②.)
2. Remove the Belt (211) of the Tape Counter.
3. Remove screw ⑧ and then remove the Plate Assembly (104) with the Dolby NR Ind. P. C. Board (PCB-6) and Rec/Pause Ind. P. C. Board (PCB-7).
4. Remove screw ⑨ and then remove the Function Switch P. C. Board (PCB-2). If necessary, unsolder the lead wires connected to the PCB-2.
5. Remove 2 screws ⑩ and then remove the Input Level Control P. C. Board (PCB-4). If necessary, unsolder the lead wires connected to the PCB-4.
6. Remove 2 screws ⑪ and then remove the VR P. C. Board (PCB-3) with the Bracket (184). If necessary, unsolder the lead wires connected to the PCB-3.

**POWER CORD REPLACEMENT (FOR SERVICE ENGINEERS OTHER THAN NORTH AMERICA)**

In order to prevent fire or shock hazard when replacing the power cord, follow the procedure below to replace the parts with the standard supply parts.

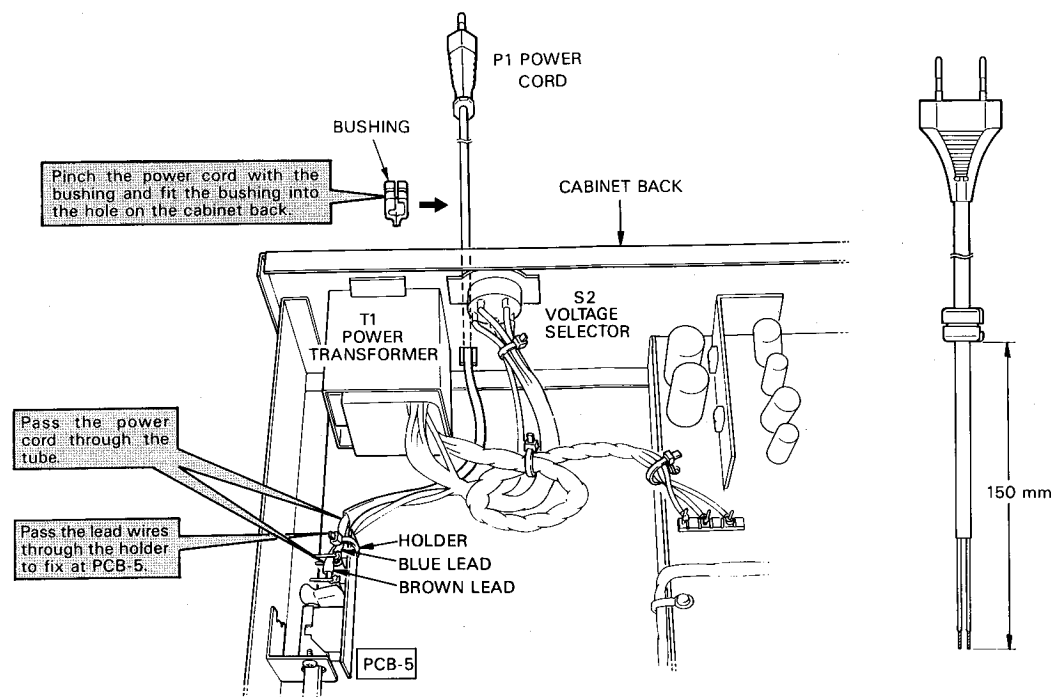

**GENERAL UNIT PARTS LIST**

Ref.No.	Part No.	Description	Ref.No.	Part No.	Description
101	A414-TD302A	Cabinet Top Ass'y	159	1660-00901	Push Button, Play U G
102	A443-TD302A	Front Panel Ass'y U G	159	1660-00902	Push Button, Play BK GB
102	A443-TD302B	Front Panel Ass'y BK GB	175	2114-01224	Bushing
103	A453-TD302A	Sub-Panel Lid Ass'y U G	180	2211-7268	Chassis
103	A453-TD302B	Sub-Panel Lid Ass'y BK GB	181	2215-7005	Bracket
104	A513-TD302A	Plate Ass'y	183	2219-8048	Bracket
105	A514-TD302A	Dressing Plate Ass'y	184	2219-8049	Bracket
106	A632-TD302A	Knob Ass'y, Bias Fine Trim, Input Balance	185	2219-8050	Bracket
107	A642-TD302A	Knob Ass'y, Input Level U G	186	2219-8051	Bracket
107	A642-TD302B	Knob Ass'y, Input Level BK GB	187	2219-8052	Bracket
108	A662-TD302A	Push Button Ass'y, Auto Repeat, Bias/Equalization, Dolby NR, NR Type U G	188	2219-7755	Bracket
108	A662-TD302D	Push Button Ass'y, Auto Repeat, Bias/Equalization, Dolby NR, NR Type BK GB	189	2218-7001	Holding Bracket
109	A662-TD302B	Push Button Ass'y, Counter Reset U G	194	2222-7186	Heat Sink
109	A662-TD302E	Push Button Ass'y, Counter Reset BK GB	195	2222-7067	Heat Sink
110	A662-TD302C	Push Button Ass'y, MPX Filter	196	2240-364	Holder
111	3112-12802	Cassette Tape Recorder Mechanism Ass'y	197	2240-7120	Holder
124	1319-0139	Foot	204	2430-7008	Special Fastener
128	1423-02301	Cabinet Bottom	205	2440-7026	Special Nut
129	1424-19601	Cabinet Back U BK	209	2601-7156	Shaft, Power Switch
129	1424-19602	Cabinet Back G GB	211	2642-01440	Belt
131	1442-10901	Panel, Input Level U G	213	2651-210189	Spring
131	1442-10902	Panel, Input Level BK GB	214	2651-2101721	Spring
139	1514-17005	Dressing Plate U G	216	2674-7020	Slider
139	1514-17006	Dressing Plate BK GB	219	2310-7025	Special Screw U G
143	1531-08501	Door Cover	219	2310-7026	Special Screw BK GB
154	1660-00401	Push Button, Power U G	227	2327-200329	Screw (2×3mm)
154	1660-00403	Push Button, Power BK GB	229	2327-300529	Screw (3×5mm)
155	1660-00501	Push Button, Eject U G	230	2327-401049	Screw (4×10mm)
155	1660-00502	Push Button, Eject BK GB	233	2343-300627	Screw (3×6mm)
158	1660-00801	Push Button, REC, FF, REW, Stop, Pause, REC Mute U G	235	2347-300846	Screw (3×8mm)
158	1660-00802	Push Button, REC, FF, REW, Stop, Pause, REC Mute BK GB	239	2347-300626	Screw (3×6mm)
			243	2347-300826	Screw (3×8mm)
			245	2347-300646	Screw (3×6mm)
			247	2347-400646	Screw (4×6mm)
			251	2440-7017	Special Nut G GB
			252	2132-01406	Spacer U G
			253	2327-301449	Screw (3×14mm)
				1111-J30241	Owner Guide U BK
				1111-J30242	Owner Guide G GB
				1221-747181	Packing Box
				1222-7284	Packing Cushion

**CASSETTE TAPE RECORDER MECHANISM PARTS LIST**

Ref.No.	Part No.	Description	Ref.No.	Part No.	Description
1	F245-011	Switch Arm, Pack	34	FP463-11	Sub Belt
2	F244-011	Switch Arm, REC	35	FF14A-11	Main Belt
3	FD35C-11	Cassette Support	36	F265-217	Solenoid, PB
4	FK568-11	Spring, Door	37	FD23E-12	PB Arm
5	EC30K-12	Eject Lock Arm	38	FK18W-12	Spring, PB Arm
6	FM296-11	Spacer	39	FR17N-11	Idle Ass'y
7	KY130-11	Connector, 8 Pos.	40	FK18R-12	Spring, Idler
8	UE13K-11	Switch	41	FC29G-14	Bracket, Door
9	FU14K-11	REC/PB Head	42	FK18N-11	Spring Head Base
10	FU192-11	Erase Head	43	FK18P-11	Spring, Assist Base
11	FK572-11	Spring, Azimuth	44	FC29M-12	Assist Base
12	FD23C-15	Head Spacer	45	FN14C-13	PB Gear
13	F105-020	Supply Reel Ass'y	46	FD24G-12	Collar
14	F123-033	Take-up Reel Ass'y	47	FK11F-51	Spring, Flywheel
15	FC29K-11	Spring Holder	48	FR17E-11	Flywheel Ass'y
16	FC29N-13	Head Base	49	UJ11S-11	Spacer
17	FD24H-12	Brake Arm (L)	50	WH20C-01	Connector, 4 Pos.
18	FD24K-12	Brake Arm (R)	51	FC29H-15	Bracket, Motor
19	FK18U-11	Spring, Brake	52	F064-179	Motor
20	F014-075	Pinch Roller	53	FP12T-12	Connector Panel
21	FK18S-11	Spring, Pinch Roller	54	FJ115-12	Cushion, Motor
22	FK18V-11	Spring, Solenoid Arm	55	KG194-12	Screw (3×6mm)
23	FK18T-14	Spring, Assist	56	FG114-15	Screw (2.6×4mm)
24	FK11F-47	Spring, Back Tension	57	UG12R-11	Screw (2×12mm)
25	FN14B-12	Idler Gear	58	KG189-11	Screw (3×5mm)
26	FK18M-11	Spring, Eject Arm	59	UG12W-12	Screw
27	F011-163	Chassis Ass'y	60	FG137-17	Screw
28	FC29E-11	Spring, Cassette	61	FJ111-18	Non-metal Washer
29	F265-216	Solenoid, FF, REW	62	FJ141-11	Oil Seal
30	FR17M-13	Clutch Ass'y	63	UJ12B-11	Lock Washer
31	FC29F-11	Bracket, Dumper	64	FJ123-14	Lock Washer
32	FP472-11	Dumper Ass'y	65	FJ123-13	Lock Washer
33	FD23B-12	FF/REW Solenoid Arm	66	FJ123-21	Lock Washer

## DISASSEMBLY PROCEDURES (REFER TO PAGES 5 AND 16)

### ① CABINET TOP ASSEMBLY (101) REMOVAL

Remove 6 screws **A** and then remove the Cabinet Top Assembly (101).

### ② FRONT PANEL ASSEMBLY (102) REMOVAL

1. Remove the Cabinet Top Assembly (101). (Refer to step ①.)
2. Remove 7 screws **B** and then remove the Front Panel Assembly (102).

### ③ CASSETTE TAPE RECORDER MECHANISM ASSEMBLY (111) REMOVAL

1. Remove the Front Panel Assembly (102). (Refer to step ②.)
2. Disconnect the LCN201 connected to the Cassette Tape Recorder Mechanism Assembly (111).
3. From the Record/Playback Head and Erase Head, unsolder the lead wires connected to the Main P. C. Board (PCB-1).
4. Loosen 8 screws **C** and then remove the Cabinet Bottom (128).
5. Remove the Belt (211) of the Tape Counter.
6. Remove 4 screws **D** and then remove the Cassette Tape Recorder Mechanism Assembly (111).

### ④ MAIN P. C. BOARD (PCB-1) REMOVAL

1. Remove the Cabinet Top Assembly (101). (Refer to step ①.)

2. Disconnect the LCN201 and LCN202 connected to the Cassette Tape Recorder Mechanism Assembly (111) and Peak Level Meter (D401).
3. Open the lid of connectors (CN103 ~ CN108, CN110, CN301 and CN302) on the Main P. C. Board (PCB-1) and disconnect the lead wires.
4. Unsolder the lead wires connected to the Main P. C. Board (PCB-1).
5. Remove 7 screws **E** and then remove the Main P. C. Board (PCB-1).

### ⑤ OTHER P. C. BOARDS REMOVAL

1. Remove the Front Panel Assembly (102). (Refer to step ②.)
2. Remove the Belt (211) of the Tape Counter.
3. Remove screw **F** and then remove the Plate Assembly (104) with the Dolby NR Ind. P. C. Board (PCB-6) and Rec/Pause Ind. P. C. Board (PCB-7).
4. Remove screw **G** and then remove the Function Switch P. C. Board (PCB-2). If necessary, unsolder the lead wires connected to the PCB-2.
5. Remove 2 screws **H** and then remove the Input Level Control P. C. Board (PCB-4). If necessary, unsolder the lead wires connected to the PCB-4.
6. Remove 2 screws **I** and then remove the VR P. C. Board (PCB-3) with the Bracket (184). If necessary, unsolder the lead wires connected to the PCB-3.

## POWER CORD REPLACEMENT (FOR SERVICE ENGINEERS OTHER THAN NORTH AMERICA)

In order to prevent fire or shock hazard when replacing the power cord, follow the procedure below to replace the parts with the standard supply parts.

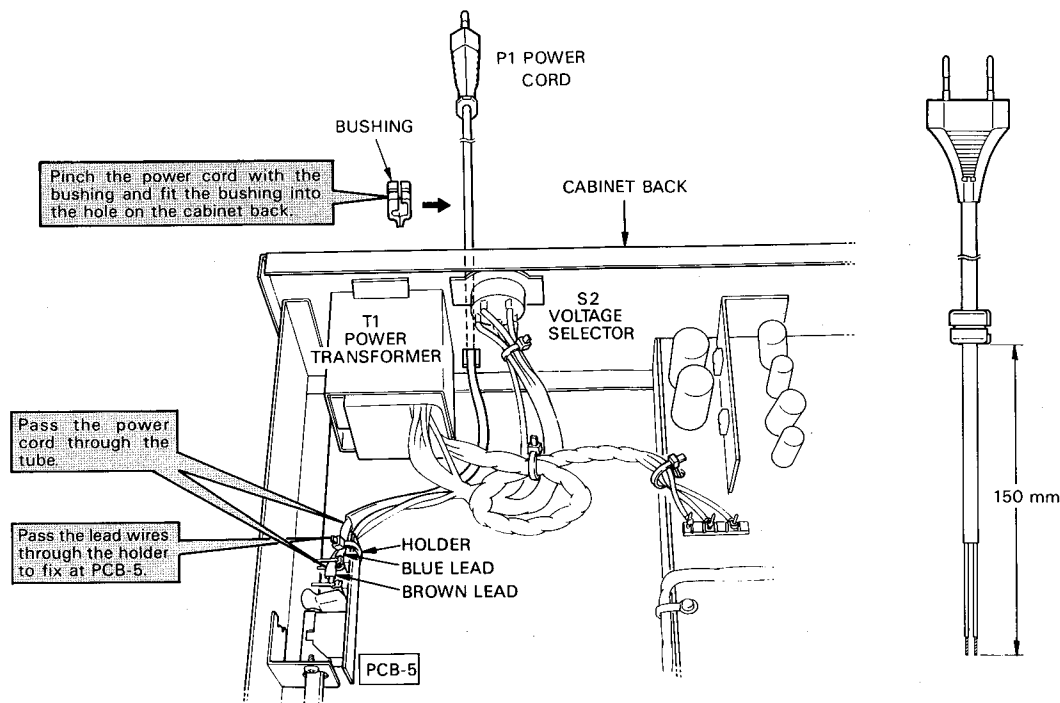

## GENERAL UNIT PARTS LIST

Ref.No.	Part No.	Description	Ref.No.	Part No.	Description
101	A414-TD302A	Cabinet Top Ass'y	159	1660-00901	Push Button, Play <b>U</b> <b>G</b>
102	A443-TD302A	Front Panel Ass'y <b>U</b> <b>G</b>	159	1660-00902	Push Button, Play <b>BK</b> <b>GB</b>
102	A443-TD302B	Front Panel Ass'y <b>BK</b> <b>GB</b>	175	2114-01224	Bushing
103	A453-TD302A	Sub-Panel Lid Ass'y <b>U</b> <b>G</b>	180	2211-7268	Chassis
103	A453-TD302B	Sub-Panel Lid Ass'y <b>BK</b> <b>GB</b>	181	2215-7005	Bracket
104	A513-TD302A	Plate Ass'y	183	2219-8048	Bracket
105	A514-TD302A	Dressing Plate Ass'y	184	2219-8049	Bracket
106	A632-TD302A	Knob Ass'y, Bias Fine Trim, Input Balance	185	2219-8050	Bracket
107	A642-TD302A	Knob Ass'y, Input Level <b>U</b> <b>G</b>	186	2219-8051	Bracket
107	A642-TD302B	Knob Ass'y, Input Level <b>BK</b> <b>GB</b>	187	2219-8052	Bracket
108	A662-TD302A	Push Button Ass'y, Auto Repeat, Bias/Equalization, Dolby NR, NR Type <b>U</b> <b>G</b>	188	2219-7755	Bracket
108	A662-TD302D	Push Button Ass'y, Auto Repeat, Bias/Equalization, Dolby NR, NR Type <b>BK</b> <b>GB</b>	189	2218-7001	Holding Bracket
109	A662-TD302B	Push Button Ass'y, Counter Reset <b>U</b> <b>G</b>	194	2222-7186	Heat Sink
109	A662-TD302E	Push Button Ass'y, Counter Reset <b>BK</b> <b>GB</b>	195	2222-7067	Heat Sink
110	A662-TD302C	Push Button Ass'y, MPX Filter	196	2240-364	Holder
111	3112-12802	Cassette Tape Recorder Mechanism Ass'y	197	2240-7120	Holder
124	1319-0139	Foot	204	2430-7008	Special Fastener
128	1423-02301	Cabinet Bottom	205	2440-7026	Special Nut
129	1424-19601	Cabinet Back <b>U</b> <b>BK</b>	209	2601-7156	Shaft, Power Switch
129	1424-19602	Cabinet Back <b>G</b> <b>GB</b>	211	2642-01440	Belt
131	1442-10901	Panel, Input Level <b>U</b> <b>G</b>	213	2651-210189	Spring
131	1442-10902	Panel, Input Level <b>BK</b> <b>GB</b>	214	2651-2101721	Spring
139	1514-17005	Dressing Plate <b>U</b> <b>G</b>	216	2674-7020	Slider
139	1514-17006	Dressing Plate <b>BK</b> <b>GB</b>	219	2310-7025	Special Screw <b>U</b> <b>G</b>
143	1531-08501	Door Cover	219	2310-7026	Special Screw <b>BK</b> <b>GB</b>
154	1660-00401	Push Button, Power <b>U</b> <b>G</b>	227	2327-200329	Screw (2×3mm)
154	1660-00403	Push Button, Power <b>BK</b> <b>GB</b>	229	2327-300529	Screw (3×5mm)
155	1660-00501	Push Button, Eject <b>U</b> <b>G</b>	230	2327-401049	Screw (4×10mm)
155	1660-00502	Push Button, Eject <b>BK</b> <b>GB</b>	233	2343-300627	Screw (3×6mm)
158	1660-00801	Push Button, REC, FF, REW, Stop, Pause, REC Mute <b>U</b> <b>G</b>	235	2347-300846	Screw (3×8mm)
158	1660-00802	Push Button, REC, FF, REW, Stop, Pause, REC Mute <b>BK</b> <b>GB</b>	239	2347-300626	Screw (3×6mm)
			243	2347-300826	Screw (3×8mm)
			245	2347-300646	Screw (3×6mm)
			247	2347-400646	Screw (4×6mm)
			251	2440-7017	Special Nut <b>G</b> <b>GB</b>
			252	2132-01406	Spacer <b>G</b> <b>GB</b>
			253	2327-301449	Screw (3×14mm)
				1111-J30241	Owner Guide <b>U</b> <b>BK</b>
				1111-J30242	Owner Guide <b>G</b> <b>GB</b>
				1221-747181	Packing Box
				1222-7284	Packing Cushion

## CASSETTE TAPE RECORDER MECHANISM PARTS LIST

Ref.No.	Part No.	Description	Ref.No.	Part No.	Description
1	F245-011	Switch Arm, Pack	34	FP463-11	Sub Belt
2	F244-011	Switch Arm, REC	35	FF14A-11	Main Belt
3	FD35C-11	Cassette Support	36	F265-217	Solenoid, PB
4	FK568-11	Spring, Door	37	FD23E-12	PB Arm
5	EC30K-12	Eject Lock Arm	38	FK18W-12	Spring, PB Arm
6	FM296-11	Spacer	39	FRI7N-11	Idler Ass'y
7	KY130-11	Connector, 8 Pos.	40	FK18R-12	Spring, Idler
8	UE13K-11	Switch	41	FC29G-14	Bracket, Door
9	FU14K-11	REC/PB Head	42	FK18N-11	Spring Head Base
10	FU192-11	Erase Head	43	FK18P-11	Spring, Assist Base
11	FK572-11	Spring, Azimuth	44	FC29M-12	Assist Base
12	FD23C-15	Head Spacer	45	FN14C-13	PB Gear
13	F105-020	Supply Reel Ass'y	46	FD24G-12	Collar
14	F123-033	Take-up Reel Ass'y	47	FK11F-51	Spring, Flywheel
15	FC29K-11	Spring Holder	48	FRI7E-11	Flywheel Ass'y
16	FC29N-13	Head Base	49	UJ11S-11	Spacer
17	FD24H-12	Brake Arm (L)	50	WH20C-01	Connector, 4 Pos.
18	FD24K-12	Brake Arm (R)	51	FC29H-15	Bracket, Motor
19	FK18U-11	Spring, Brake	52	F064-179	Motor
20	FO14-075	Pinch Roller	53	FPI2T-12	Connector Panel
21	FK18S-11	Spring, Pinch Roller	54	FJ115-12	Cushion, Motor
22	FK18V-11	Spring, Solenoid Arm	55	KG194-12	Screw (3×6mm)
23	FK18T-14	Spring, Assist	56	FG114-15	Screw (2.6×4mm)
24	FK11F-47	Spring, Back Tension	57	UG12R-11	Screw (2×12mm)
25	FN14B-12	Idler Gear	58	KG189-11	Screw (3×5mm)
26	FK18M-11	Spring, Eject Arm	59	UG12W-12	Screw
27	F011-163	Chassis Ass'y	60	FG137-17	Screw
28	FC29E-11	Spring, Cassette	61	FJ111-18	Non-metal Washer
29	F265-216	Solenoid, FF, REW	62	FJ141-11	Oil Seal
30	FRI7M-13	Clutch Ass'y	63	UJ12B-11	Lock Washer
31	FC29F-11	Bracket, Dumper	64	FJ123-14	Lock Washer
32	FP472-11	Dumper Ass'y	65	FJ123-13	Lock Washer
33	FD23B-12	FF/REW Solenoid Arm	66	FJ123-21	Lock Washer



**GENERAL UNIT EXPLODED VIEW**

1  
2  
3  
4  
5  
6  
7

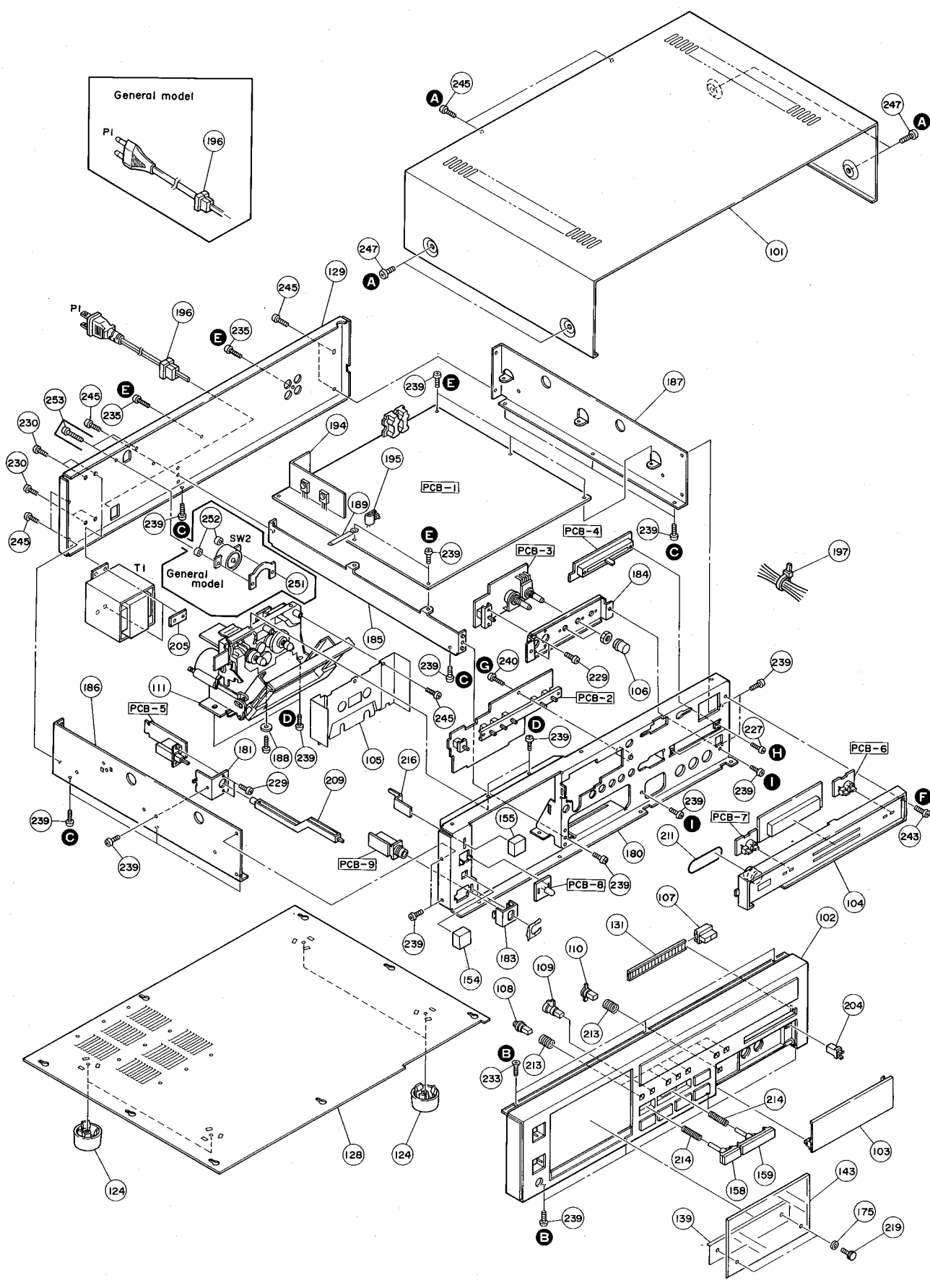

**CASSETTE TAPE RECORDER MECHANISM EXPLODED VIEW**

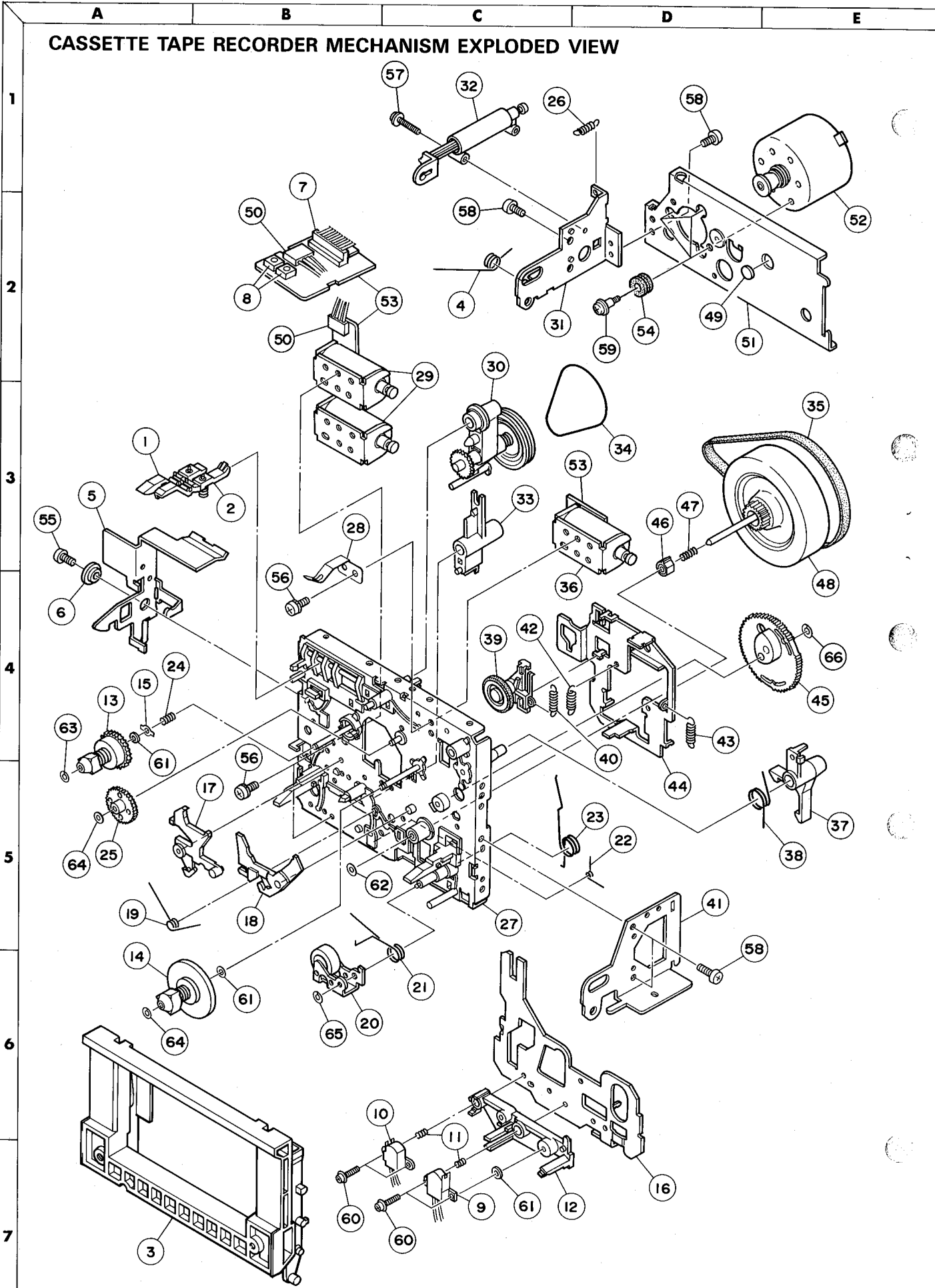

## CIRCUIT DESCRIPTION

### Playback Signal

The playback signal from the playback head is amplified in the playback amplifiers Q101, Q103, Q105 (L ch.), Q102, Q104 and Q106 (R ch.) and fed to the IC501 (Dolby NR circuit). The signal enters pin ③ of IC501 where it is encoded and output through pin ⑨. The output signal is fed from pin ⑨ to the OUTPUT jack, IC301 (headphone amplifier) and METER.

The characteristics of the playback equalizer are selected by the BIAS EQUALIZATION switch, by means of Q107 (L ch.) and Q108 (R ch.).

### Record Signal

The input signal coming through the INPUT jacks is adjusted by INPUT LEVEL and INPUT BALANCE and fed to IC501 (Dolby NR circuit). The signal enters pin ① of IC501, is decoded and fed through the MPX filter. The output signal appears on pin ⑫.

The output signal passes through the record equalizer circuit, amplified in the record amplifier IC201, combined with the bias signal and fed to the record head.

### Muting Operation

The Record/Playback switch control signal and mute signal are obtained from IC801 of the logic control block.

The signal output through pin ⑨ of IC801 turns Q804 and 805 to ON, whereby the mute signal is output. At the power ON/OFF, however, the mute signal is from Q51. When the STOP button is pressed, this mute signal turns Q711 (L ch.) and Q712 (R ch.) ON to short-circuit the output signal for muting.

### Logic in Record Mode

When the REC button is pressed, pin ⑮ of IC801 becomes low level and causes Q801 and Q802 to turn ON, and REC and REC signals are generated. The REC signal causes the bias circuit to turn ON and the REC signal turns Q705, 707 (L ch.) and Q706 and 708 (R ch.) ON to short-circuit the input and output signals of the playback amplifiers.

Also, the REC signal switches Q803 OFF. As the PLAY signal turns OFF thereby, Q701, Q703 (L ch.), Q702, 704 (R ch.) and Q709 (L ch.), 710 (R ch.) switch off, resulting in the record mode.

### Logic in Playback Mode

With the STOP, PAUSE or PLAY button pressed, Q803 becomes ON (OFF when pin ⑮ of IC801 is low level), the PLAY signal is output and Q701, 703 (L ch.) and Q702, 704 (R ch.) turn ON. Then the output side of the IC201 is short-circuited and at the same time one side of the record/playback head is short-circuited to the ground. Also, Q709 (L ch.), 710 (R ch.) are turned ON to short-circuit the input side of the IC201, resulting in the playback mode.

## BLOCK DIAGRAM

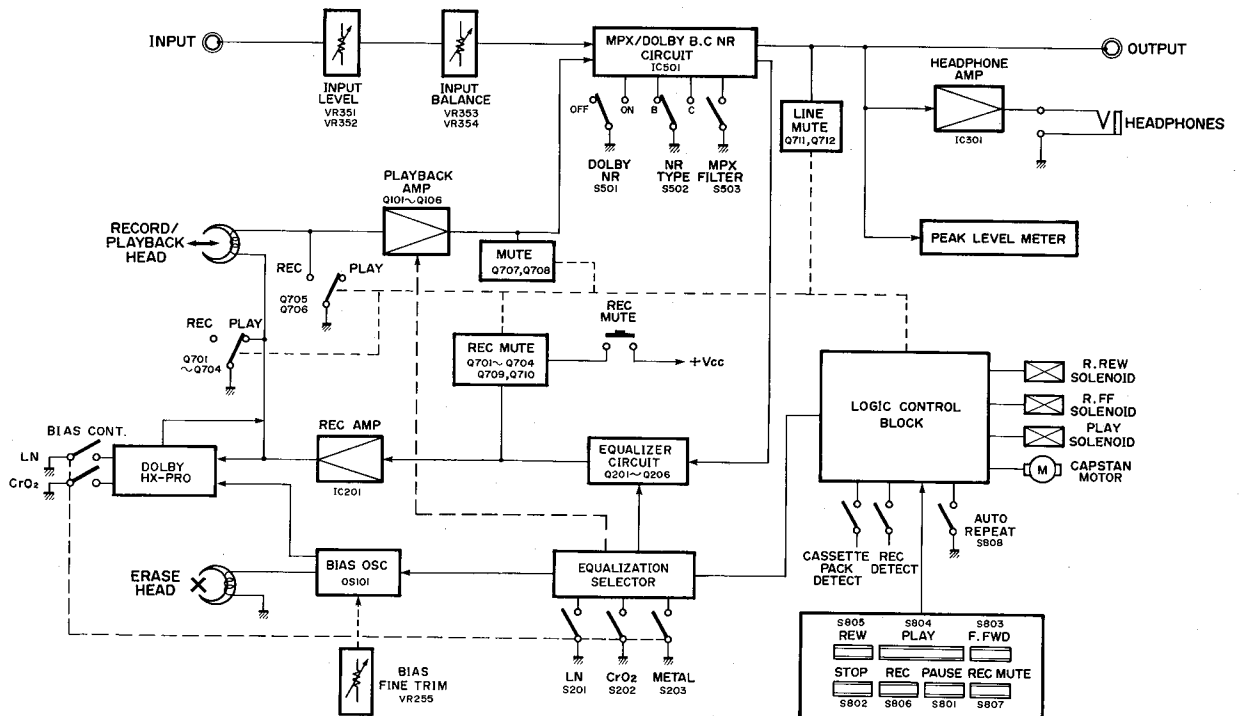

TIMING CHART

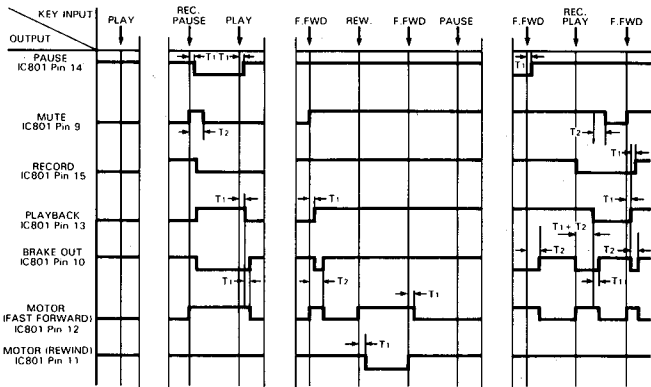
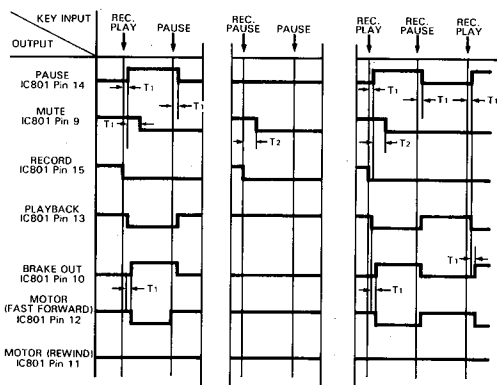
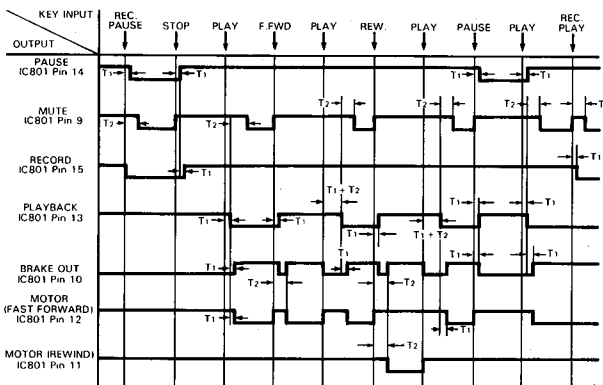
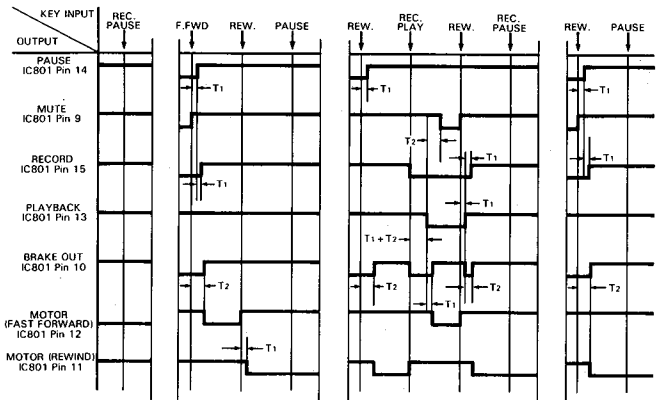
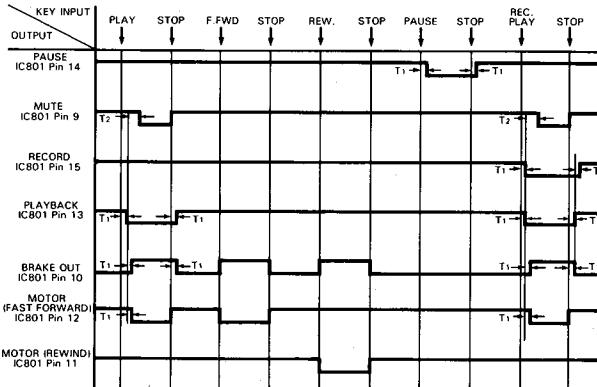

NOTE  
 After the power switch is pushed on, the unit remains in stop mode for about 1.6 second. After that, it operates according to each input key as shown in figure. During this 1.6 second all input keys are ineffective.

T1 = 61 (msec)  
 T2 = 400 (msec)

**ALIGNMENT PROCEDURES (REFER TO PAGES 15, 17 AND 18)**

**■ CASSETTE MECHANISM CONFIRMATION**

Make sure to confirm conditions of the cassette mechanism as follows before adjustment.

**1. Confirmation of erroneous erase preventive function**

- The switch should turn ON when a tape with erroneous erase preventive pawl is inserted. (Use a tape which is 0.2mm smaller than the minimum size of 62.9mm or a MAZ-0184-C gauge one.)

**2. Confirmation of cassette pack detection function**

- The switch should turn ON when a tape is inserted. (Use a tape whose minimum size is 63.5mm or a MAZ-0184-C gauge one.)
- When the turn arm is moved back gradually from the ON position, the switch should turn OFF.

**3. Confirmation of eject function**

- The cassette compartment opens smoothly and no abnormal noise should be heard while opening and closing.
- The eject lock arm opens smoothly without contacting the chassis and damper.
- The eject button can not be pressed during playback.

**4. Confirmation of playback, fast forward and rewind functions**

- The torque used in each of the playback, fast forward and rewind modes should be within specification.  
 Playback ..... 35gr. cm ~ 70gr. cm  
 Fast Forward ..... 70gr. cm ~ 150gr. cm  
 Rewind ..... 70gr. cm ~ 150gr. cm
- No abnormal noise should be heard in operation in any mode. The solenoid switching sound should not be considered as a noise.

**5. Confirmation of positions of record/playback head and erase head**

**• Head height**

- Set the M-300 head gauge.
- Set the unit in the playback mode and place the adjustment chip on the head gauge as shown in the Fig. 1.
- The adjustment chip should not contact the tape guide of both record/playback head and erase head.

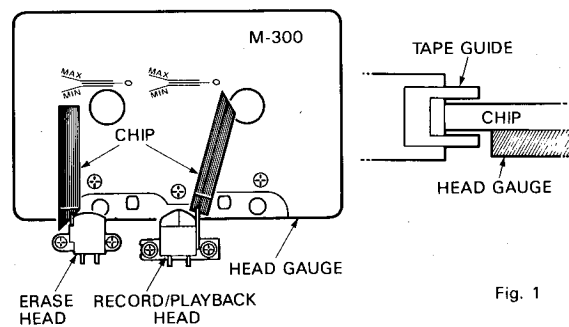

Fig. 1

**• Head position**

- Set the M-300 head gauge.
- Set the unit in the playback mode and place the adjustment chip on the head gauge as shown in the Fig. 2.
- With both record/playback head and erase head, the adjustment chip should be between MIN and MAX of the M-300 head gauge.

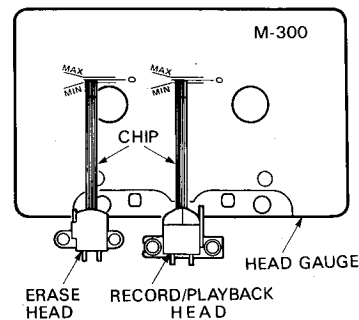

Fig. 2

**■ ELECTRICAL ADJUSTMENT AND CONFIRMATION**

**1. Before adjustment**

- Before electrical adjustment, make sure that confirmations of the cassette mechanism are all completed.
- After the power switch is pushed on, wait for 10 minutes before measuring to be sure of the most stable operation.
- Since head magnetization, dust accumulations, etc. are likely to introduce errors in the various characteristics, it is very important that the heads are properly demagnetized and cleaned before commencing any adjustment, particularly frequency response and head azimuth adjustment.

**2. Instruments required**

- Low frequency oscillator
- AC VTVM or dual channel AC VTVM
- Oscilloscope
- Wow/flutter meter
- Frequency counter

**3. Test tapes**

- Azimuth adjustment ..... MTT-114
- Tape speed adjustment ..... MTT-111 or MTT-111D
- Playback output level adjustment ..... MTT-150 or TCC-130
- Playback frequency characteristic confirmation ..... TCC-288H or TCC-162C, TCC-262C
- Reference tapes  
 LN ..... SCC-502  
 CrO<sub>2</sub> ..... SCC-504  
 METAL ..... SCC-565

**Note:**

C-90 differs with C-60 in the thickness and bias is of unequal, so adjust with the tape whose bias is of specified value.

**4. General conditions (unless otherwise noted)**

Controls and Switches	Settings
Dolby NR	Off
Input Level	Maximum
MPX Filter	Off
Bias Fine Trim	Center
Input Balance	Center

**Azimuth Adjustment**

When the maximum level point of R channel does not equal that L channel, connect the oscilloscope as shown in Fig. 3 and proceed with azimuth adjustment so that L and R channels are in phase.

- Connect L channel tape out to "X (or V)" and R channel to "Y (or H)". Observe the lissajous waveform.
- Set L and R channels to monaural. Adjust vertical and horizontal gain so that the waveform becomes 45 degree.
- Adjust azimuth so that the measurement of "a" becomes maximum and the measurement of "b" becomes minimum against the 45 degree line.

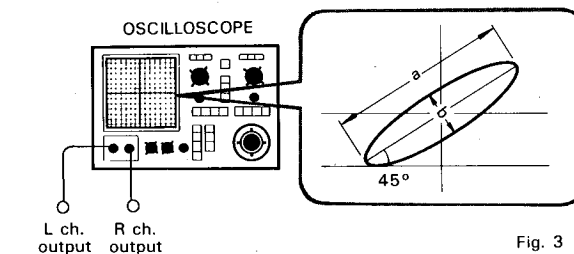
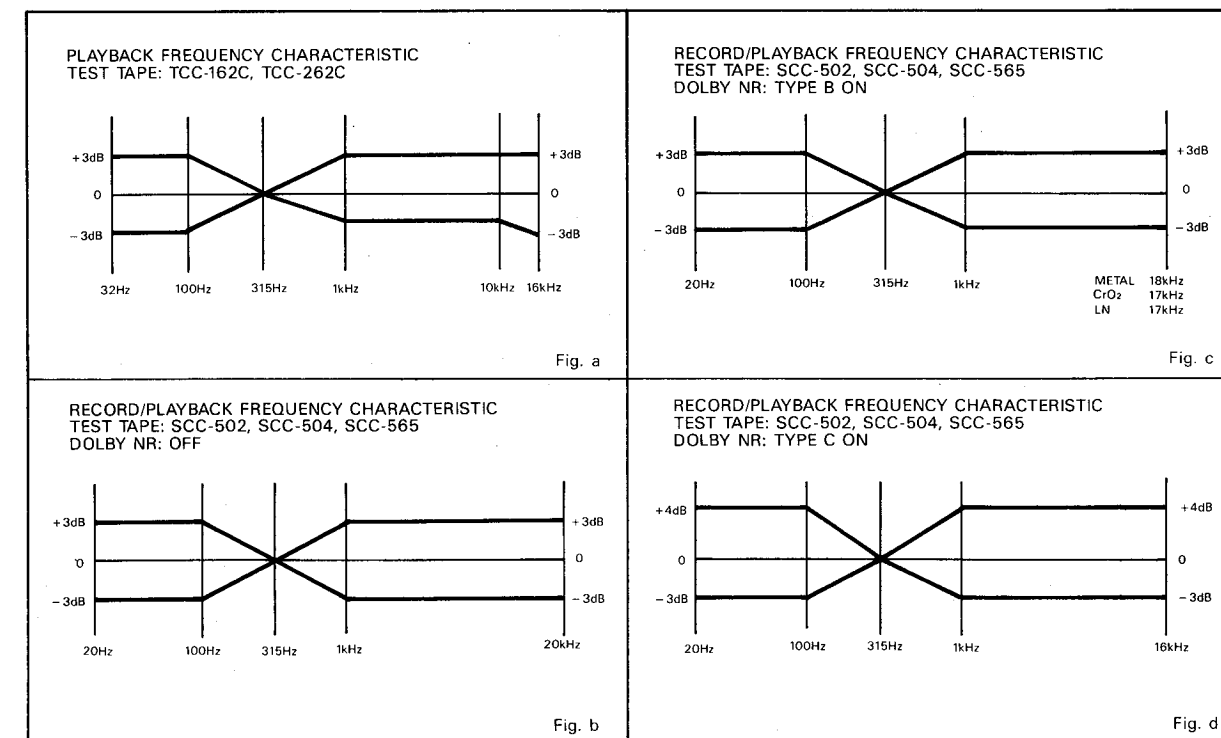

Fig. 3



## ALIGNMENT PROCEDURES (REFER TO PAGES 15, 17 AND 18)

### ■ CASSETTE MECHANISM CONFIRMATION

Make sure to confirm conditions of the cassette mechanism as follows before adjustment.

#### 1. Confirmation of erroneous erase preventive function

- The switch should turn ON when a tape with erroneous erase preventive pawl is inserted. (Use a tape which is 0.2mm smaller than the minimum size of 62.9mm or a MAZ-0184-C gauge one.)

#### 2. Confirmation of cassette pack detection function

- The switch should turn ON when a tape is inserted. (Use a tape whose minimum size is 63.5mm or a MAZ-0184-C gauge one.)
- When the switch arm is moved back gradually from the ON position, the switch should turn OFF.

#### 3. Confirmation of eject function

- The cassette compartment opens smoothly and no abnormal noise should be heard while opening and closing.
- The eject lock arm opens smoothly without contacting the chassis and damper.
- The eject button can not be pressed during playback.

#### 4. Confirmation of playback, fast forward and rewind functions

- The torque used in each of the playback, fast forward and rewind modes should be within specification.  
Playback ..... 35gr. cm ~ 70gr. cm  
Fast Forward ..... 70gr. cm ~ 150gr. cm  
Rewind ..... 70gr. cm ~ 150gr. cm
- No abnormal noise should be heard during operation in any mode. The solenoid switching sound should not be considered as a noise.

#### 5. Confirmation of positions of record/playback head and erase head

##### • Head height

- Set the M-300 head gauge.
- Set the unit in the playback mode and place the adjustment chip on the head gauge as shown in the Fig. 1.
- The adjustment chip should not contact the tape guide of both record/playback head and erase head.

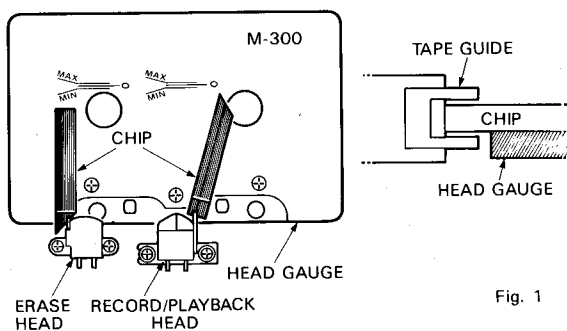

Fig. 1

##### • Head position

- Set the M-300 head gauge.
- Set the unit in the playback mode and place the adjustment chip on the head gauge as shown in the Fig. 2.
- With both record/playback head and erase head, the adjustment chip should be between MIN and MAX of the M-300 head gauge.

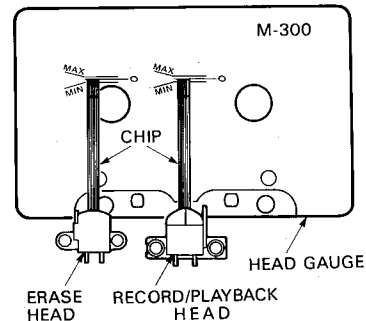

Fig. 2

**■ ELECTRICAL ADJUSTMENT AND CONFIRMATION**

**1. Before adjustment**

- Before electrical adjustment, make sure that confirmations of the cassette mechanism are all completed.
- After the power switch is pushed on, wait for 10 minutes before measuring to be sure of the most stable operation.
- Since head magnetization, dust accumulations, etc. are likely to introduce errors in the various characteristics, it is very important that the heads are properly demagnetized and cleaned before commencing any adjustment, particularly frequency response and head azimuth adjustment.

**2. Instruments required**

- Low frequency oscillator
- AC VTVM or dual channel AC VTVM
- Oscilloscope
- Wow/flutter meter
- Frequency counter

**3. Test tapes**

- Azimuth adjustment ..... MTT-114
- Tape speed adjustment ..... MTT-111 or MTT-111D
- Playback output level adjustment ..... MTT-150 or TCC-130
- Playback frequency characteristic confirmation ..... TCC-288H or TCC-162C, TCC-262C
- Reference tapes
  - LN ..... SCC-502
  - CrO<sub>2</sub> ..... SCC-504
  - METAL ..... SCC-565

**Note:**

C-90 differs with C-60 in the thickness and bias is of unequal, so adjust with the tape whose bias in of specified value.

**4. General conditions (unless otherwise noted)**

Controls and Switches	Settings
Dolby NR	Off
Input Level	Maximum
MPX Filter	Off
Bias Fine Trim	Center
Input Balance	Center

**Azimuth Adjustment**

When the maximum level point of R channel does not equal that L channel, connect the oscilloscope as shown in Fig. 3 and proceed with azimuth adjustment so that L and R channels are in phase.

- Connect L channel tape out to "X (or V)" and R channel to "Y (or H)". Observe the lissajous waveform.
- Set L and R channels to monaural. Adjust vertical and horizontal gain so that the waveform becomes 45 degree.
- Adjust azimuth so that the measurement of "a" becomes maximum and the measurement of "b" becomes minimum against the 45 degree line.

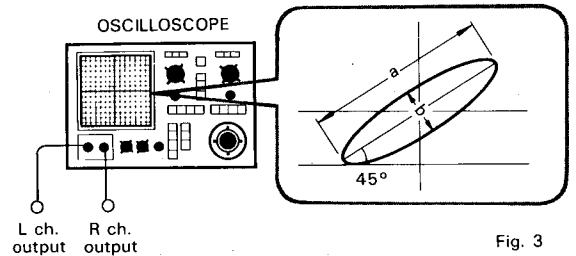

Fig. 3

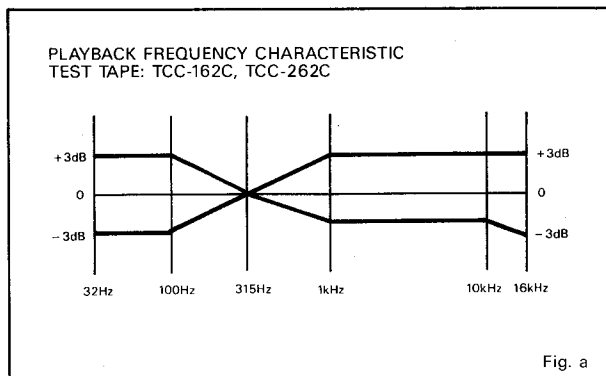

Fig. a

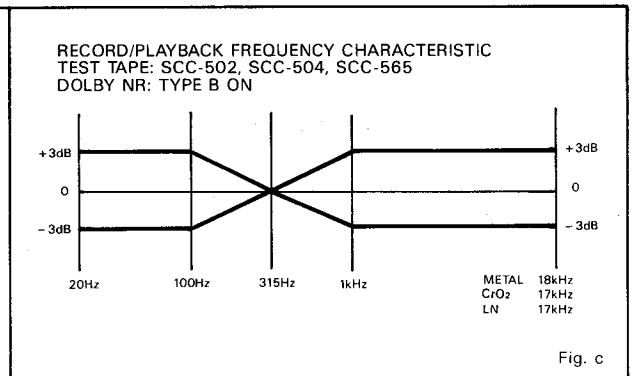

Fig. c

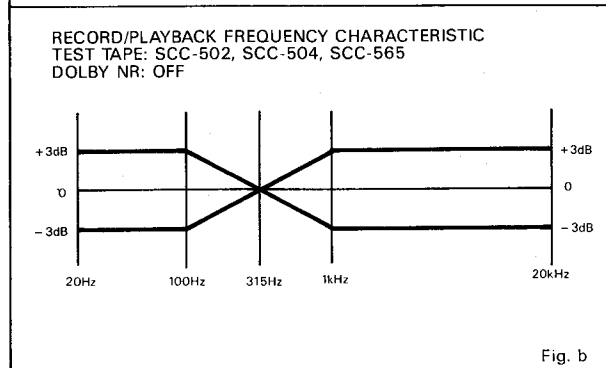

Fig. b

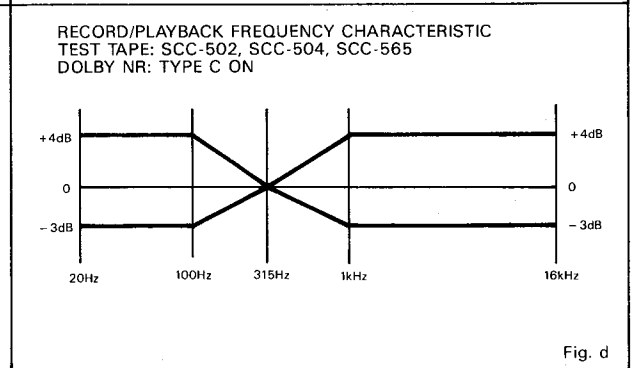

Fig. d

Step	Alignment	Instrument Required	Input Signal	Mode	Test Point	Adjustment	For
1	Azimuth	VTVM Oscilloscope Test tape (MTT-114)		PB	TP1 TP2	Azimuth screw	Maximum output Refer to "Azimuth adjustment" on page 9.
2	Tape speed	Frequency counter Test tape (MTT-111 or MTT-111D)		PB	TP1 TP2	VR built in motor	3000Hz $\pm$ 10Hz Adjust at the center of test tape.
3	Playback output level	VTVM Test tape (MTT-150 or TCC-130)		PB	TP1 TP2	VR101 VR102	300mV
4	Playback frequency characteristic	VTVM Test tape (TCC-288H or TCC- 162C and TCC-262C)		PB	OUTPUT jack	VR103 VR104	+0.5dB ~ -2dB (at 1kHz to 20kHz)
5	Step up trans	VTVM Blank tape (SCC-565)		REC- PAUSE	TP101 TP102	L651, L203 L652, L204	Maximum output Set the Bias Fine Trim to the "hi cut" position. Set the VR251 all the way to counterclockwise. Set the VR252 all the way to clockwise. Tape selector is metal position.
6	Bias trap	VTVM Blank tape (SCC-565)		REC- PAUSE	TP253 TP254	L205 L206	Minimum output Set the Bias Fine Trim to the "hi cut" position. Set the VR251 all the way to counterclockwise. Set the VR252 all the way to clockwise. Tape selector is metal position.
7	Bias level (pre-adjustment)	VTVM Blank tapes (metal SCC-565 CrO <sub>2</sub> SCC-504 LN SCC-502)		REC- PAUSE	TP101 TP102	VR251 VR252	110mV Tape selector is metal position.
						VR253 VR254	56mV Tape selector is CrO <sub>2</sub> position.
						VR257 VR258	34mV Tape selector is LN position.
8	Bias frequency confirmation	Frequency counter		REC- PAUSE	TP251		105kHz $\pm$ 5kHz Tape selector is metal position.
9	Record level (pre-adjustment)	VTVM Blank tape (SCC-504)	Apply 400Hz signal to INPUT jack. Set INPUT LEVEL knob so that TP3 and TP4 voltage is 300mV in REC-PAUSE mode.	REC/PB	TP1 TP2	VR201 VR202	300mV Tape selector is CrO <sub>2</sub> position.
10	Peaking coil (pre-adjustment)	VTVM Blank tape (SCC-565)	Apply 400Hz signal to INPUT jack. Set INPUT LEVEL knob so that TP101 and TP102 voltage is 300mV - 25dB in REC mode.	REC- PAUSE	TP101 TP102	L201 L202	So that output becomes maximum at 22kHz input. Disconnect the connector (CN110). Tape selector is metal position.
11	Record/playback equalizer frequency characteristic	VTVM Blank tapes (metal SCC-565 CrO <sub>2</sub> SCC-504 LN SCC-502)	Apply 400Hz signal to INPUT jack. Set INPUT LEVEL knob so that TP3 and TP4 voltage is 300mV - 25dB in REC-PAUSE mode. Then adjust with a 20Hz to 30kHz sweep signal.	REC/PB	OUTPUT jack	VR251 L201	So that the record/playback frequency response is flat (at least within the range in Fig. b). Tape selector is metal position.
						VR252 L202	
						VR253 L201	So that the record/playback frequency response is flat (at least within the range in Fig. b). Tape selector is CrO <sub>2</sub> position.
						VR254 L202	
VR257 VR258	So that the record/playback frequency response is flat (at least within the range in Fig. b). Tape selector is LN position.						
L201 L202	So that the record/playback frequency is balanced at each position of metal and CrO <sub>2</sub> .						
12	Record level	VTVM Blank tape (SCC-504)	Apply 400Hz signal to INPUT jack. Set INPUT LEVEL knob so that TP3 and TP4 voltage is 300mV - 25dB in REC-PAUSE mode. Then adjust with a 20Hz to 30kHz sweep signal.	REC/PB	TP1 TP2	VR201 VR202	300mV Tape selector is CrO <sub>2</sub> position.
13	Record level confirmation	VTVM Blank tapes (metal SCC-565 LN SCC-502)	Apply 400Hz signal to INPUT jack. Set INPUT LEVEL knob so that TP3 and TP4 voltage is 300mV - 25dB in REC-PAUSE mode. Then adjust with a 20Hz to 30kHz sweep signal.	REC/PB	TP1 TP2		300mV $\pm$ 1dB This confirmation should be done at each tape selector position of metal and LN.
14	Record/playback equalizer frequency characteristic confirmation	VTVM Blank tapes (metal SCC-565 CrO <sub>2</sub> SCC-504 LN SCC-502)	Apply 400Hz signal to INPUT jack. Set INPUT LEVEL knob so that TP3 and TP4 voltage is 300mV - 25dB in REC-PAUSE mode. Then adjust with a 20Hz to 30kHz sweep signal.	REC/PB	OUTPUT jack		Confirm that the record/playback frequency response is within the range in Fig. c and Fig. d. If it is not within the specification, redo the adjustment and confirmation in steps 10, 11, 12 and 13. This confirmation should be done at each tape selector position under each of the following conditions, Dolby NR B type on and Dolby NR C type on.
15	Meter level	VTVM	Apply 400Hz signal to INPUT jack. Set INPUT LEVEL knob so that TP3 and TP4 voltage is 300mV - 0.5dB in REC-PAUSE mode.	REC- PAUSE	PEAK LEVEL METER	VR401 VR402	Adjust to the point where the 0dB LED of the peak level meter lights.
16	MPX filter characteristic confirmation	VTVM	Apply 19kHz and 15kHz signal to INPUT jack. Set INPUT LEVEL knob so that TP3 and TP4 voltage is 300mV in REC-PAUSE mode.	REC- PAUSE	OUTPUT jack		Confirm that attenuation of 15kHz and 19kHz is within the specification when MPX filter on.
17	Anti skwing level confirmation	VTVM	Apply 400Hz signal to INPUT jack. Set INPUT LEVEL knob so that TP3 and TP4 voltage is 300mV - 25dB in REC-PAUSE mode.	REC- PAUSE	TP201 TP202		Confirm that attenuation of 20kHz is maximum. Dolby NR C type is on.



Step	Alignment	Instrument Required	Input Signal
1	Azimuth	VTVM Oscilloscope Test tape (MTT-114)	
2	Tape speed	Frequency counter Test tape (MTT-111 or MTT-111D)	
3	Playback output level	VTVM Test tape (MTT-150 or TCC-130)	
4	Playback frequency characteristic	VTVM Test tape (TCC-288H or TCC-162C and TCC-262C)	
5	Step up trans	VTVM Blank tape (SCC-565)	
6	Bias trap	VTVM Blank tape (SCC-565)	
7	Bias level (pre-adjustment)	VTVM Blank tapes (metal SCC-565) (CrO <sub>2</sub> SCC-504) (LN SCC-502)	
8	Bias frequency confirmation	Frequency counter	
9	Record level (pre-adjustment)	VTVM Blank tape (SCC-504)	Apply 400Hz signal to INPUT jack. Set INPUT LEVEL knob so that TP3 and TP4 voltage is 300mV in REC-PAUSE mode.
10	Peaking coil (pre-adjustment)	VTVM Blank tape (SCC-565)	Apply 400Hz signal to INPUT jack. Set INPUT LEVEL knob so that TP101 and TP102 voltage is 300mV - 25dB in REC mode.
11	Record/playback equalizer frequency characteristic	VTVM Blank tapes (metal SCC-565) (CrO <sub>2</sub> SCC-504) (LN SCC-502)	Apply 400Hz signal to INPUT jack. Set INPUT LEVEL knob so that TP3 and TP4 voltage is 300mV - 25dB in REC-PAUSE mode. Then adjust with a 20Hz to 30kHz sweep signal.
12	Record level	VTVM Blank tape (SCC-504)	Apply 400Hz signal to INPUT jack. Set INPUT LEVEL knob so that TP3 and TP4 voltage is 300mV - 25dB in REC-PAUSE mode. Then adjust with a 20Hz to 30kHz sweep signal.
13	Record level confirmation	VTVM Blank tapes (metal SCC-565) (LN SCC-502)	Apply 400Hz signal to INPUT jack. Set INPUT LEVEL knob so that TP3 and TP4 voltage is 300mV - 25dB in REC-PAUSE mode. Then adjust with a 20Hz to 30kHz sweep signal.
14	Record/playback equalizer frequency characteristic confirmation	VTVM Blank tapes (metal SCC-565) (CrO <sub>2</sub> SCC-504) (LN SCC-502)	Apply 400Hz signal to INPUT jack. Set INPUT LEVEL knob so that TP3 and TP4 voltage is 300mV - 25dB in REC-PAUSE mode. Then adjust with a 20Hz to 30kHz sweep signal.
15	Meter level	VTVM	Apply 400Hz signal to INPUT jack. Set INPUT LEVEL knob so that TP3 and TP4 voltage is 300mV - 0.5dB in REC-PAUSE mode.
16	MPX filter characteristic confirmation	VTVM	Apply 19kHz and 15kHz signal to INPUT jack. Set INPUT LEVEL knob so that TP3 and TP4 voltage is 300mV in REC-PAUSE mode.
17	Anti skwing level confirmation	VTVM	Apply 400Hz signal to INPUT jack. Set INPUT LEVEL knob so that TP3 and TP4 voltage is 300mV - 25dB in REC-PAUSE mode.

		Mode	Test Point	Adjustment	For
		PB	TP1 TP2	Azimuth screw	Maximum output Refer to "Azimuth adjustment" on page 9.
		PB	TP1 TP2	VR built in motor	3000Hz $\pm$ 10Hz Adjust at the center of test tape.
		PB	TP1 TP2	VR101 VR102	300mV
		PB	OUTPUT jack	VR103 VR104	+0.5dB ~ -2dB (at 1kHz to 20kHz)
		REC- PAUSE	TP101 TP102	L651, L203 L652, L204	Maximum output Set the Bias Fine Trim to the "hi cut" position. Set the VR251 all the way to counterclockwise. Set the VR252 all the way to clockwise. Tape selector is metal position.
		REC- PAUSE	TP253 TP254	L205 L206	Minimum output Set the Bias Fine Trim to the "hi cut" position. Set the VR251 all the way to counterclockwise. Set the VR252 all the way to clockwise. Tape selector is metal position.
		REC- PAUSE	TP101 TP102	VR251 VR252	110mV Tape selector is metal position.
				VR253 VR254	56mV Tape selector is CrO2 position.
				VR257 VR258	34mV Tape selector is LN position.
		REC- PAUSE	TP251		105kHz $\pm$ 5kHz Tape selector is metal position.
is 300mV in		REC/PB	TP1 TP2	VR201 VR202	300mV Tape selector is CrO2 position.
knob so that		REC- PAUSE	TP101 TP102	L201 L202	So that output becomes maximum at 22kHz input. Disconnect the connector (CN110). Tape selector is metal position.
		REC/PB	OUTPUT jack	VR251 L201	So that the record/playback frequency response is flat (at least within the range in Fig. b). Tape selector is metal position.
				VR252 L202	
				VR253 L201	So that the record/playback frequency response is flat (at least within the range in Fig. b). Tape selector is CrO2 position.
				VR254 L202	
				VR257 VR258	So that the record/playback frequency response is flat (at least within the range in Fig. b). Tape selector is LN position.
			L201 L202	So that the record/playback frequency is balanced at each position of metal and CrO2.	
		REC/PB	TP1 TP2	VR201 VR202	300mV Tape selector is CrO2 position.
		REC/PB	TP1 TP2		300mV $\pm$ 1dB This confirmation should be done at each tape selector position of metal and LN.
		REC/PB	OUTPUT jack		Confirm that the record/playback frequency response is within the range in Fig. c and Fig. d. If it is not within the specification, redo the adjustment and confirmation in steps 10, 11, 12 and 13. This confirmation should be done at each tape selector position under each of the following conditions, Dolby NR B type on and Dolby NR C type on.
		REC- PAUSE	PEAK LEVEL METER	VR401 VR402	Adjust to the point where the 0dB LED of the peak level meter lights.
		REC- PAUSE	OUTPUT jack		Confirm that attenuation of 15kHz and 19kHz is within the specification when MPX filter on.
		REC- PAUSE	TP201 TP202		Confirm that attenuation of 20kHz is maximum. Dolby NR C type is on.

## ELECTRICAL PARTS LIST

Ref.No.	Part No.	Description	Ref.No.	Part No.	Description
<b>CHASSIS MISCELLANEOUS</b>					
△	PI	4161-71151			Power Cord <b>U</b> <b>BK</b>
△	PI	4161-7256			Power Cord <b>G</b> <b>GB</b>
△	T1	5584-702376			Power Trans. <b>U</b> <b>BK</b>
△	T1	5584-703392			Power Trans. <b>G</b> <b>GB</b>
△	S2	4411-102729			Rotary Switch, Voltage Selector <b>G</b> <b>GB</b>
△	F1	5732-102052			Fuse, TIA <b>G</b> <b>GB</b>
△	F2	5732-102052			Fuse, TIA <b>G</b> <b>GB</b>
	D401	5623-LT1151			Peak Level Meter
		4161-71184			Connection Cord (Accessory)
<b>PCB-1 MAIN P.C. BOARD</b>					
<b>RESISTORS</b>					
△	R12	5102-2205114			22Ω, 1/2W, FR
△	R51	5102-4R74715			4.7Ω, 1/4W, FR
△	R52	5102-4R74715			4.7Ω, 1/4W, FR
△	R137	5102-4R74715			4.7Ω, 1/4W, FR
△	R252	5102-8204715			82Ω, 1/4W, FR
△	R253	5102-8204715			82Ω, 1/4W, FR
△	R313	5102-1014715			100Ω, 1/4W, FR
△	R314	5102-1014715			100Ω, 1/4W, FR
	R513	5174-332381			3.3kΩ, 1/4W, MR
	R514	5174-332381			3.3kΩ, 1/4W, MR
	R515	5174-102381			1kΩ, 1/4W, MR
	R516	5174-102381			1kΩ, 1/4W, MR
	R522	5174-203381			20kΩ, 1/4W, MR
△	R530	5102-1004715			10Ω, 1/4W, FR
△	R667	5102-1014715			100Ω, 1/4W, FR
△	R668	5102-1014715			100Ω, 1/4W, FR
△	R673	5102-1004715			10Ω, 1/4W, FR
△	R674	5102-1004715			10Ω, 1/4W, FR
<b>CONTROLS</b>					
	VR101	5101-20371920			20kΩB
	VR102	5101-20371920			20kΩB
	VR103	5101-20201927			2kΩ
	VR104	5101-20201927			2kΩ
	VR201	5101-20271927			2kΩB
	VR202	5101-20271927			2kΩB
	VR251	5101-20371920			20kΩB
	VR252	5101-20371920			20kΩB
	VR253	5101-10301927			10kΩ
	VR254	5101-10301927			10kΩ
	VR257	5101-50201927			5kΩB
	VR258	5101-50201927			5kΩB
	VR401	5101-30371920			30kΩ
	VR402	5101-30371920			30kΩ
<b>CAPACITORS</b>					
	C4	5345-228D041			2200μF/25V, EC
	C5	5345-228D041			2200μF/25V, EC
	C6	5345-477C041			470μF/16V, EC
	C7	5345-477C041			470μF/16V, EC
	C8	5345-108C041			1000μF/16V, EC
	C9	5345-108C041			1000μF/16V, EC
	C51	5345-226F041			22μF/50V, EC
	C52	5345-226D041			22μF/25V, EC
	C101	5353-101534			100pF/500V, MC
	C102	5353-101534			100pF/500V, MC
	C103	5345-226C0951			22μF/16V, EC
	C104	5345-226C0951			22μF/16V, EC
	C105	5345-107B041			100μF/10V, EC
	C106	5345-107B041			100μF/10V, EC
	C107	5359-6825851			6800pF/100V, PC
	C108	5359-6825851			6800pF/100V, PC
	C109	5359-6825851			6800pF/100V, PC
	C110	5359-6825851			6800pF/100V, PC
	C111	5345-106C0951			10μF/16V, EC
	C112	5345-106C0951			10μF/16V, EC
	C113	5359-1825851			1800pF/100V, PC
	C114	5359-1825851			1800pF/100V, PC
	C115	5345-477C041			470μF/16V, EC
	C116	5345-336C041			33μF/16V, EC
	C201	5359-4715851			470pF/100V, EC
	C202	5359-4715851			470pF/100V, PC
	C209	5359-3315851			330pF/100V, PC
	C210	5359-3315851			330pF/100V, PC
	C211	5345-105F0951			1μF/50V, EC
	C212	5345-105F0951			1μF/50V, EC
	C213	5345-226C0952			22μF/16V, EC
	C214	5345-226C0952			22μF/16V, EC
	C219	5342-225F041			2.2μF/50V, EC
	C220	5342-225F041			2.2μF/50V, EC
	C223	5345-107C041			100μF/16V, EC
	C224	5345-107C041			100μF/16V, EC
	C229	5359-2215851			220pF/100V, PC
	C230	5359-2215851			220pF/100V, PC
	C251	5342-476C041			47μF/16V, EC
	C252	5342-476D041			47μF/25V, EC
	C253	5345-225F041			2.2μF/50V, EC
	C254	5345-475C041			4.7μF/16V, EC
	C255	5342-335C041			3.3μF/16V, EC
	C301	5345-106C041			10μF/16V, EC
	C302	5345-106C041			10μF/16V, EC
	C303	5345-336C041			33μF/16V, EC
	C304	5345-336C041			33μF/16V, EC
	C305	5345-107C041			100μF/16V, EC
	C306	5345-107C041			100μF/16V, EC
	C401	5345-105F041			1μF/50V, EC
	C402	5345-105F041			1μF/50V, EC
	C403	5345-226C041			22μF/16V, EC
	C404	5345-226C041			22μF/16V, EC
	C507	5345-106C0951			10μF/16V, EC
	C508	5345-106C0951			10μF/16V, EC
	C509	5345-477C041			470μF/16V, EC
	C511	5345-106C0951			10μF/16V, EC
	C512	5345-106C0951			10μF/16V, EC
	C513	5345-106C0951			10μF/16V, EC
	C514	5345-106C0951			10μF/16V, EC
	C515	5345-477C041			470μF/16V, EC
	C516	5345-226C041			22μF/16V, EC
	C517	5345-106C041			10μF/16V, EC
	C518	5345-106C041			10μF/16V, EC
	C519	5345-226C0951			22μF/16V, EC
	C520	5345-226C0951			22μF/16V, EC
	C521	5359-103741			0.01μF/100V, PC
	C522	5359-103741			0.01μF/100V, PC
	C523	5345-105F0952			1μF/50V, EC
	C524	5345-105F0952			1μF/50V, EC
	C527	5345-684F0952			0.68μF/50V, EC
	C528	5345-684F0952			0.68μF/50V, EC
	C529	5345-225F0952			2.2μF/50V, EC
	C530	5345-225F0952			2.2μF/50V, EC
	C533	5359-103741			0.01μF/100V, PC
	C534	5359-103741			0.01μF/100V, PC
	C537	5345-684F0952			0.68μF/50V, EC
	C538	5345-684F0952			0.68μF/50V, EC
	C539	5345-225F0952			2.2μF/50V, EC
	C540	5345-225F0952			2.2μF/50V, EC
	C541	5345-106C0951			10μF/16V, EC
	C542	5345-106C0951			10μF/16V, EC
	C543	5345-106C0951			10μF/16V, EC
	C544	5345-106C0951			10μF/16V, EC
	C546	5345-476C041			47μF/16V, EC
	C651	5359-2715851			270pF/100V, PC
	C652	5359-2715851			270pF/100V, PC
	C661	5359-4715851			470pF/100V, PC
	C662	5359-4715851			470pF/100V, PC
	C665	5353-101534			100pF/500V, MC
	C666	5353-101534			100pF/500V, MC



Ref.No.	Part No.	Description
<b>MISCELLANEOUS</b>		
LC501	5214-84	LC Components
LC502	5214-84	LC Components
LC503	5214-77	LC Components
LC504	5214-77	LC Components
OS101	6171-1508	Bias Osc.
J351/ J352/ J353/ J354	4484-45	4-Pin Jack, Input, Output
LCN201	4163-0822029	CLW, 8 Pos.
LCN202	4163-0812029	CLW, 8 Pos.
CN103	4443-050185	Connector, 5 Pos.
CN104	4443-050185	Connector, 5 Pos.
CN105	4443-030185	Connector, 3 Pos.
CN106	4443-030185	Connector, 3 Pos.
CN107	4443-080185	Connector, 8 Pos.
CN108	4443-030185	Connector, 3 Pos.
CN110	4443-030185	Connector, 3 Pos.
CN111	4443-030185	Connector, 3 Pos.
CN301	4443-030185	Connector, 3 Pos.
CN302	4443-030185	Connector, 3 Pos.
	2132-7048	Spacer, R12
	4472-0131	Fuse Holder <b>G</b> <b>GB</b>

#### PCB-2 FUNCTION SWITCH P.C. BOARD

C569	5345-335F041	Capacitor, 3.3 $\mu$ F/50V, EC
MR801	5193-DM106A	Magnet Resistor
S201	4431-05107160	Push Switch, LN
S202	4431-05107160	Push Switch, CrO <sub>2</sub>
S203	4431-05107160	Push Switch, Metal
S501	4431-04087171	Push Switch, Dolby NR
S502	4431-05107160	Push Switch, NR Type
S801	4431-A010131	Push Switch, Pause
S802	4431-A010131	Push Switch, Stop
S803	4431-A010131	Push Switch, F. FWD
S804	4431-A010131	Push Switch, Play
S805	4431-A010131	Push Switch, REW
S806	4431-A010131	Push Switch, REC
S807	4431-A010131	Push Switch, REC Mute
S808	4431-A027136	Push Switch, Auto Repeat

#### PCB-3 VR P.C. BOARD

VR255	5113-20271159	Control, 2k $\Omega$ B, Bias Fine Trim
VR353	5113-10471158	Control, 100k $\Omega$ MN, Input Balance
VR354		
S503	4431-A027336	Push Switch MPX Filter

#### PCB-4 INPUT LEVEL CONTROL P.C. BOARD

VR351, VR352	5224-503719	Control, 50k $\Omega$ A, Input Level
-----------------	-------------	-----------------------------------------

#### PCB-5 POWER SWITCH P.C. BOARD

$\Delta$ R13	5135-335J50P	Resistor, 3.3M $\Omega$ , 1/2W, CAR <b>G</b> <b>GB</b>
$\Delta$ C1	5361-1030419	Capacitor, 0.01 $\mu$ F/AC 125V, CC <b>U</b> <b>BK</b>
$\Delta$ C1	5352-1030958	Capacitor, 0.01 $\mu$ F/AC 250V, MPC <b>G</b> <b>GB</b>
$\Delta$ S1	4431-A01056	Push Switch, Power

#### PCB-6 DOLBY NR IND. P.C. BOARD

D402	5637-GL9PG19	LED, GL9PG19, Green Dolby B
D406	5637-GL9HY9	LED, GL9HY9, Amber, Dolby C

Ref.No. Part No. Description

#### PCB-7 REC/PAUSE IND. P.C. BOARD

D403	5637-GL9PR9	LED, GL9PR9, Red, REC Level
D404	5637-GL9HY9	LED, GL9HY9, Amber, Pause

#### PCB-8 POWER IND. P.C. BOARD

D405	5637-GL5HD5	LED, GL5HD5, Red, Power
------	-------------	-------------------------

#### PCB-9 HEADPHONES JACK P.C. BOARD

J301	4451-00159	Jack, Headphones
------	------------	------------------

#### KEY TO ABBREVIATIONS

FR	: Fuse Resistor
MR	: Metal Resistor
CR	: Cement Resistor
CAR	: Carbon Resistor
EC	: Electrolytic Capacitor
PC	: Polypropylene Capacitor
MC	: Mica Capacitor
CC	: Ceramic Capacitor
MPC	: Metalized Polyester Capacitor
ZD	: Zener Diode
CLW	: Connector with Lead Wire

**U** : U.S.A. model

**BK** : U.S.A. model Black Version

**G** : General model

**GB** : General model Black Version

\* The part with the above mark is used only in the model made for the particular market the mark indicates.

**!** SAFETY RELATED COMPONENT. USE ONLY EXACT REPLACEMENT PART AS SPECIFIED.

IC BLOCK DIAGRAM

IC201 : M5219P  
 IC301 : M5216P  
 IC651, 652 : HA17082P  
 IC653 : M5218P

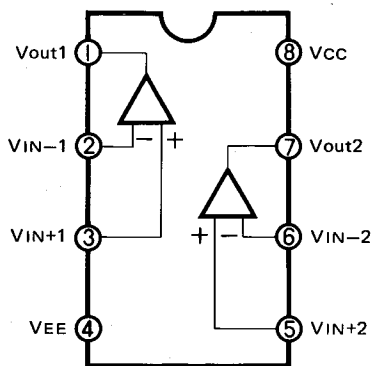

IC501 : HA12088

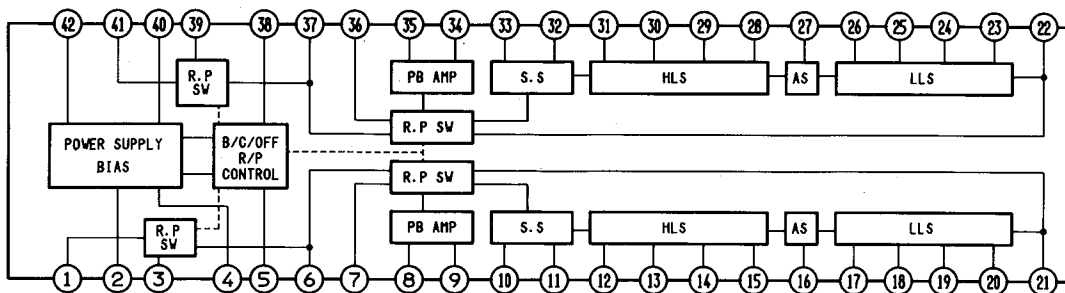

IC801 : M54886P

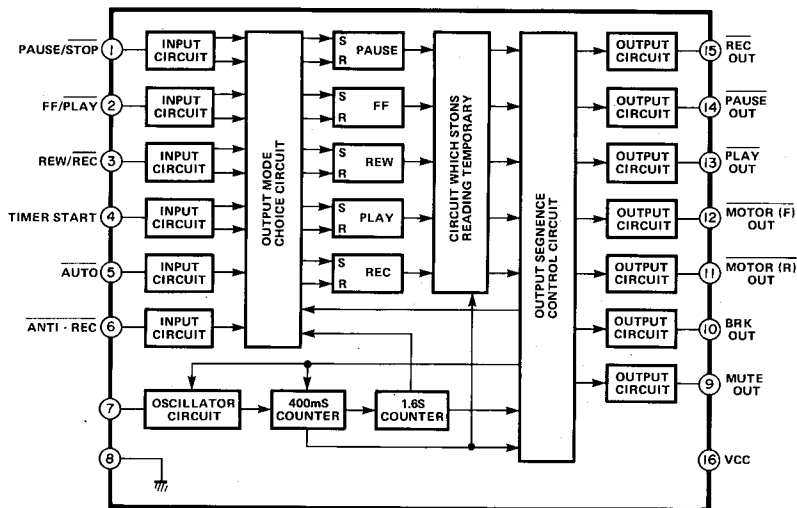

IC802 : BA335

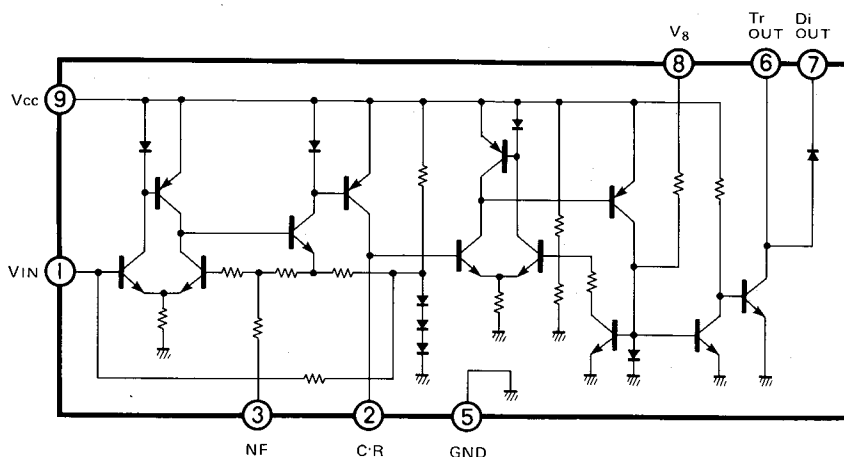

P. C. BOARDS

PCB-1 Main P. C. Board

OUTPUT LEFT RIGHT J2 INPUT LEFT RIGHT

PCB-2 Function Switch P. C. Board

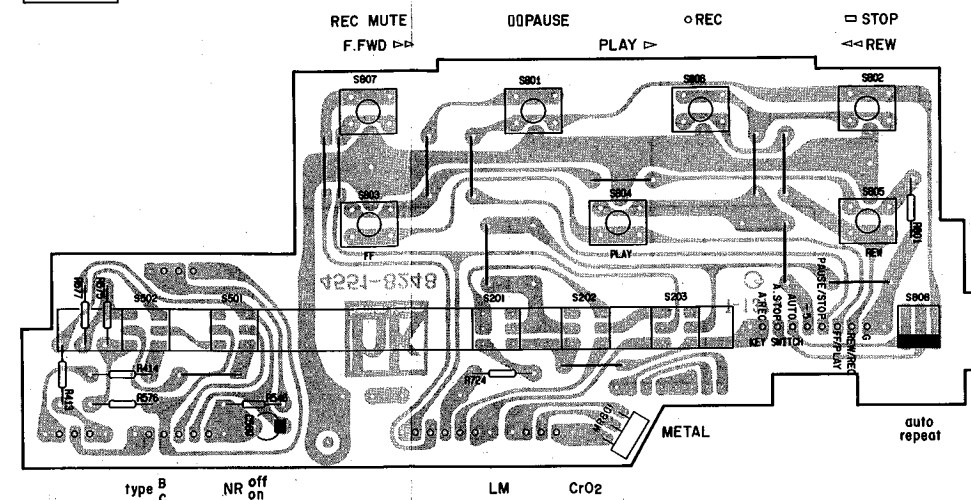

PCB-3 VR P. C. Board

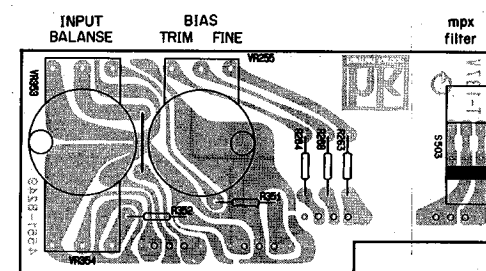

PCB-4 Input Level Control P. C. Board

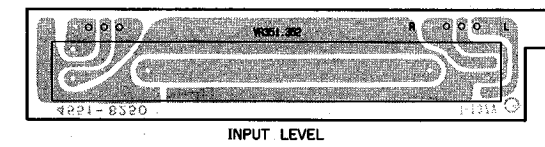

PCB-6 Dolby NR Ind. P. C. Board

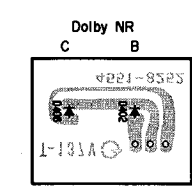

PCB-7 Rec/Pause Ind. P. C. Board

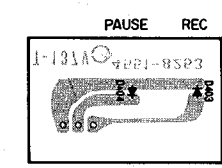

PCB-5 Power Switch P. C. Board

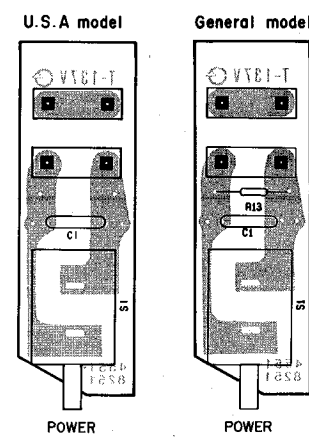

PCB-8 Power Ind. P. C. Board

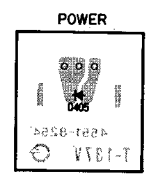

PCB-9 Headphones Jack P. C. Board

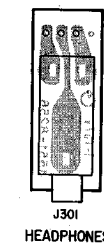

NOTE: In the figures of the P. C. Boards, a mark is provided on the base side of the transistor.

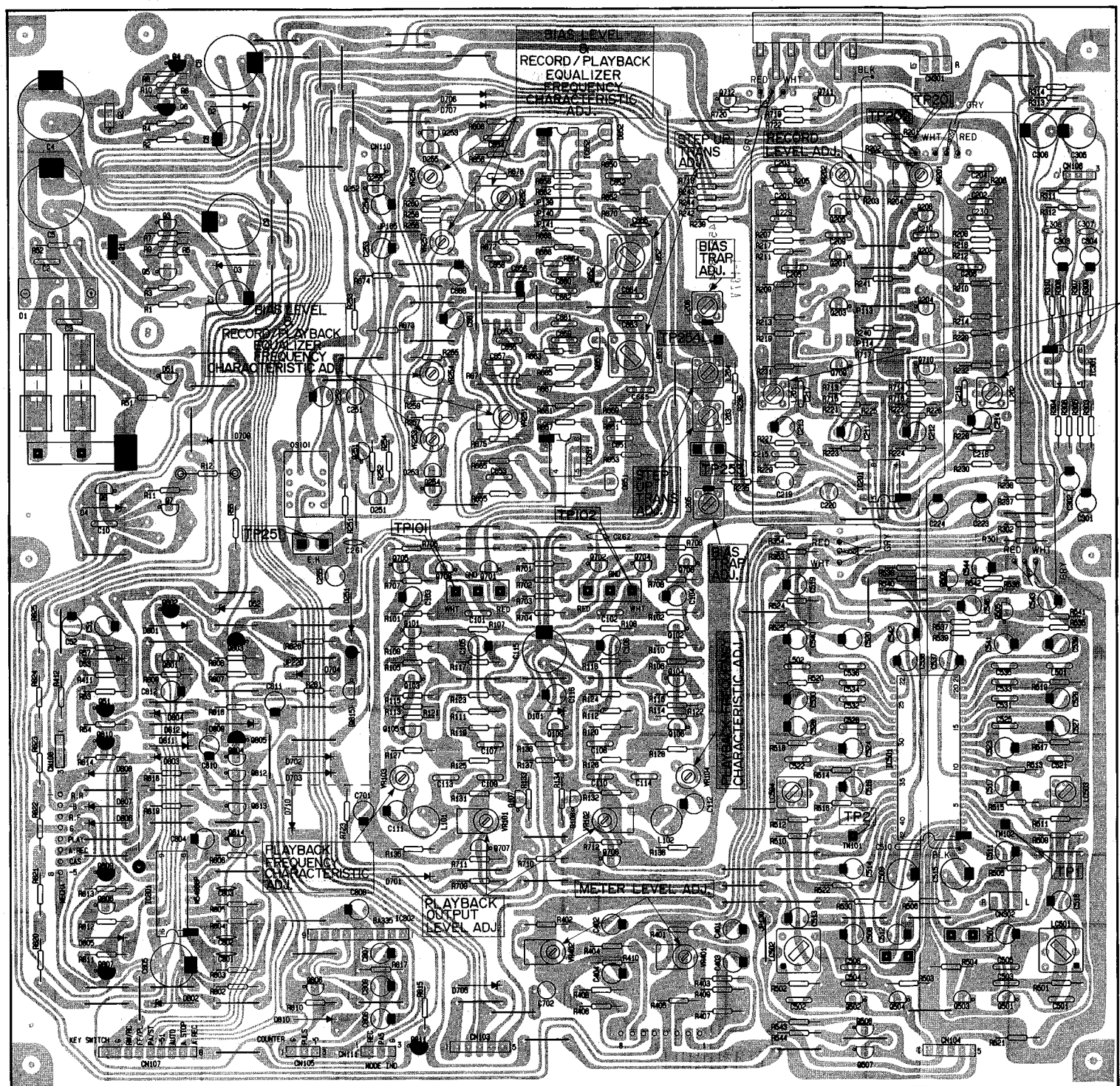
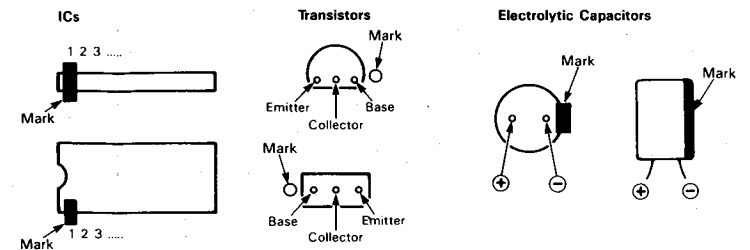

PIN CONNECTION DIAGRAM OF TRANSISTORS, DIODES AND ICs.

2SA1359 2SC3422	2SC2236 2SA970	2SC2603 2SA1115 RN1203 RN2203 2SC3378	HZ12C2L RD12EB2 IS2473 HZ11B2L RD2.7 EB2	RD5.1 EB2 S5566B IS2471	MC921 MC931 MC911	M5219P M5216P M5218P HA17082P	HA12058
2SC3246 2SC1775 2SC2320L 2SC1845	2SC2878 2SB561 2SA1335	1RBA	GL9PG19 GL9HY9 GL9PR9	GL5HD5	M5486P	BA335	



**P. C. BOARDS**

**PCB-1 Main P. C. Board**

OUTPUT LEFT RIGHT J2 INPUT LEFT RIGHT

1  
2  
3  
4  
5  
6  
7

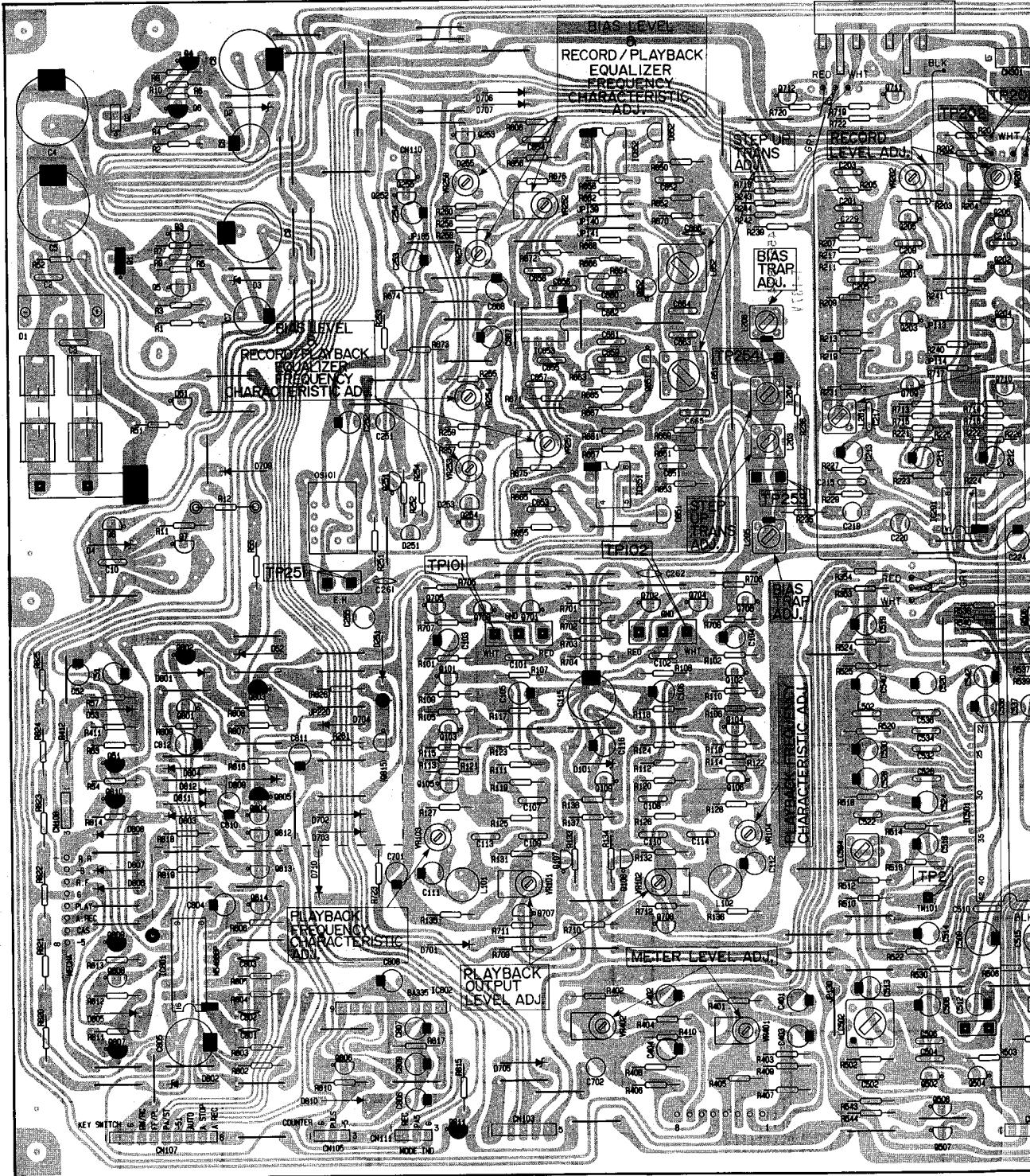

**PIN CONNECTION DIAGRAM OF TRANSISTORS, DIODES AND ICs.**

2SA1359 2SC3422 	2SC2236 2SA970 	2SC2603 2SA1115 RN1203 RN2203 2SC3378 	HZ12C2L RD12EB2 1S2473 HZ11B2L RD2.7 EB2 	RD5.1 EB2 S5566B IS2471 	MC921 MC931 MC911 
2SC3246 2SC1775 2SC2320L 2SC1845 2SC2878 2SB561 2SA1335 	S1RBA 	GL9PG19 GL9HY9 GL9PR9 	GL5HD5 	M5486P 	



E F G H I J

**PCB-2 Function Switch P. C. Board**

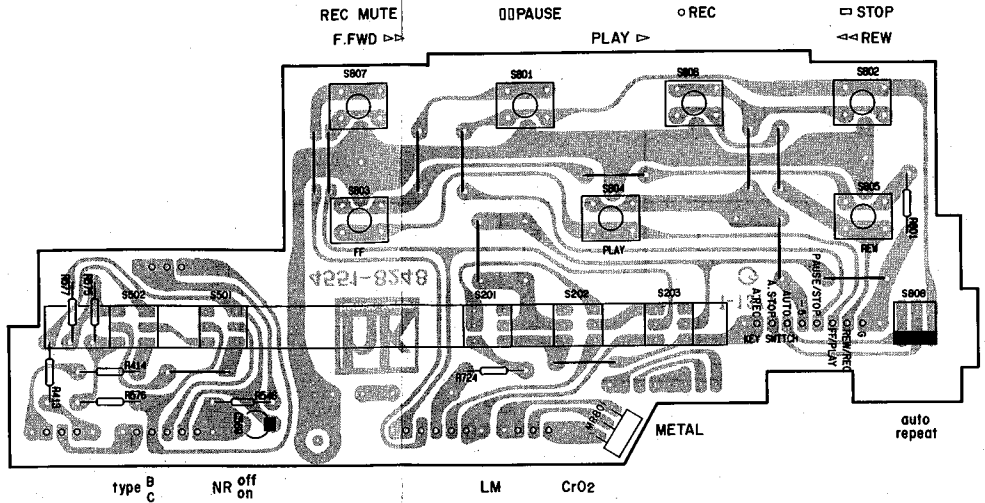

**PCB-3 VR P. C. Board**

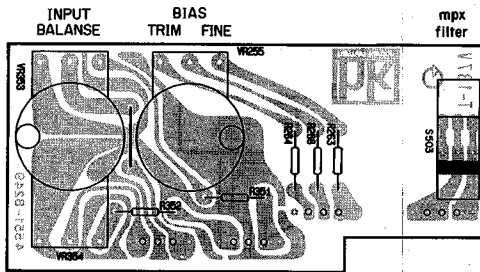

**PCB-4 Input Level Control P. C. Board**

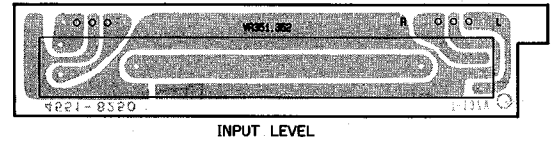

**PCB-6 Dolby NR Ind. P. C. Board**

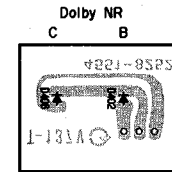

**PCB-7 Rec/Pause Ind. P. C. Board**

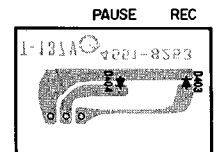

**PCB-5 Power Switch P. C. Board**

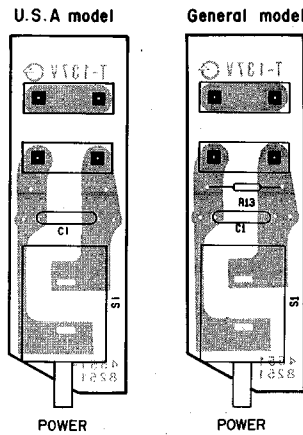

**PCB-8 Power Ind. P. C. Board**



**PCB-9 Headphones Jack P. C. Board**



**NOTE:**  
 In the figures of the P. C. Boards, a mark is provided on the base side of the transistor.

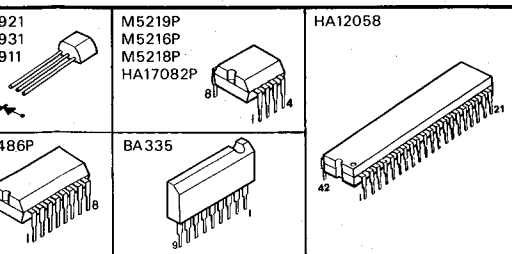
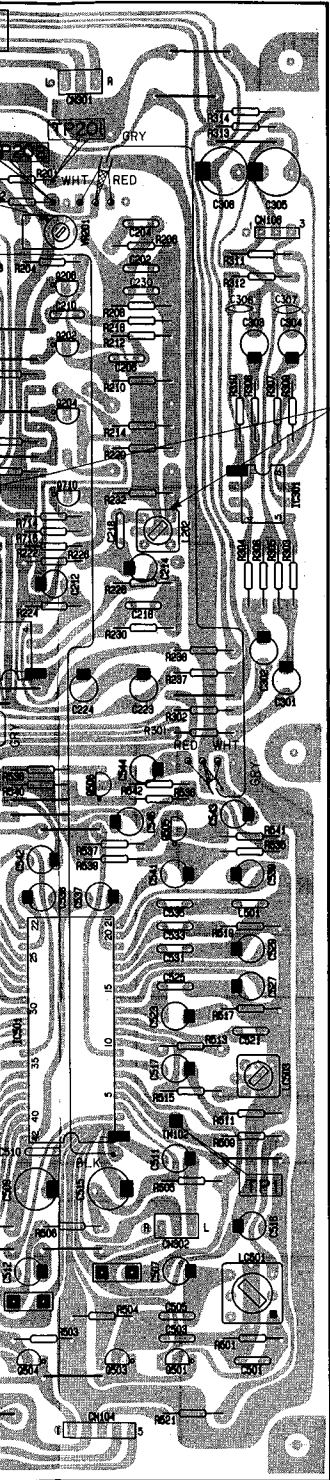
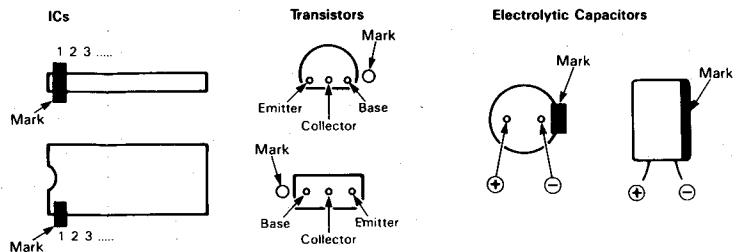

WIRING DIAGRAM

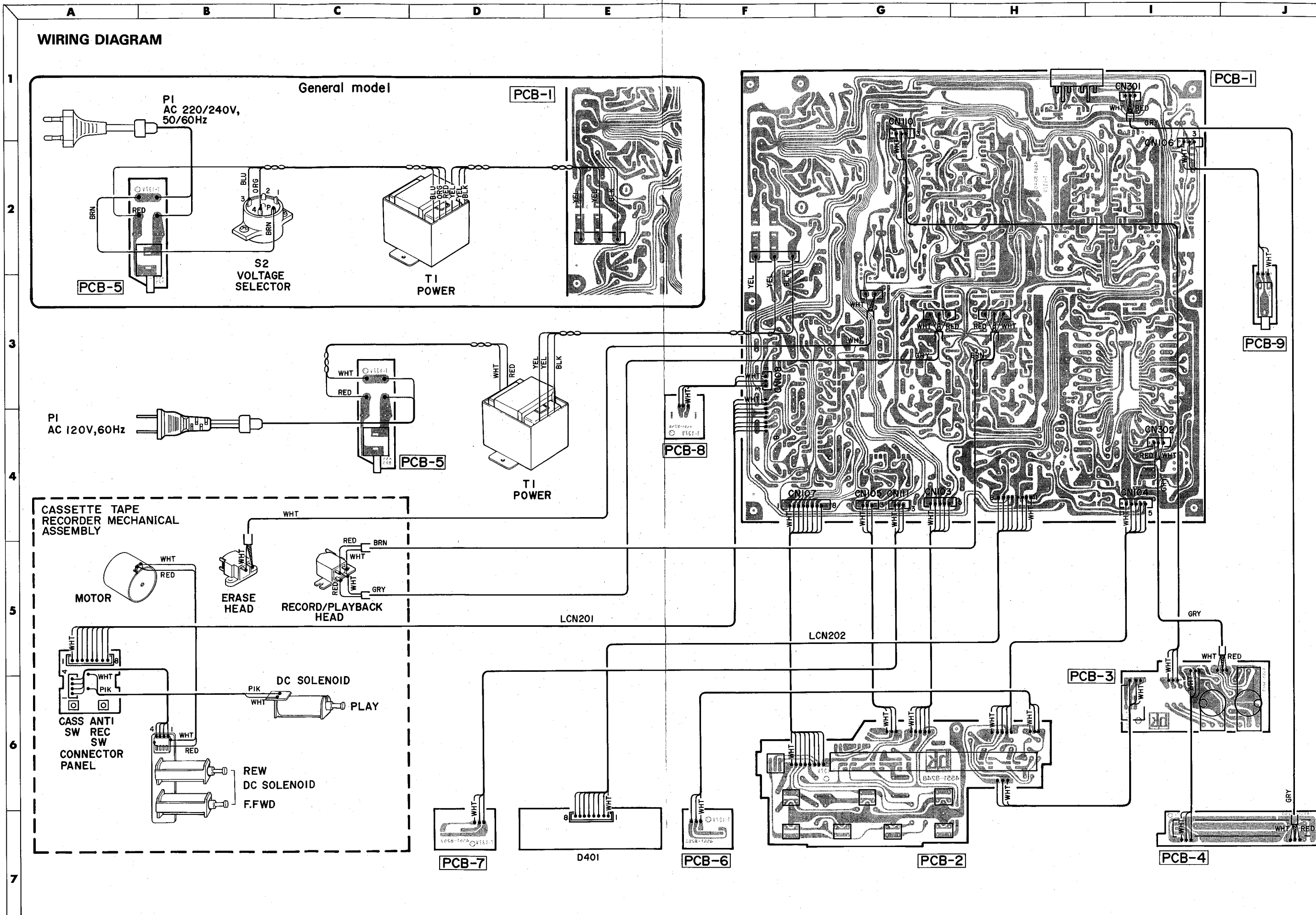

WIRING DIAGRAM

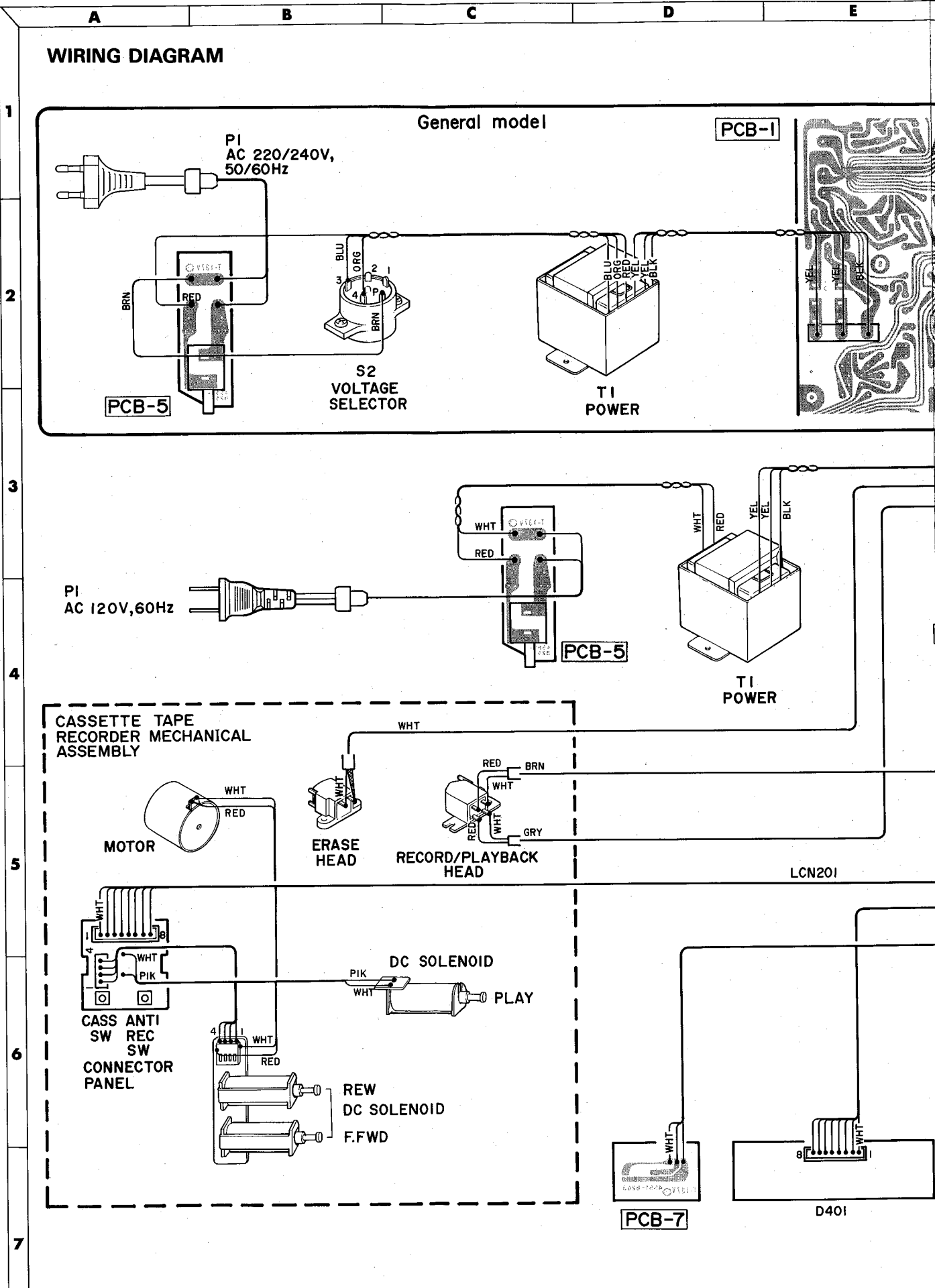

F

G

H

I

J

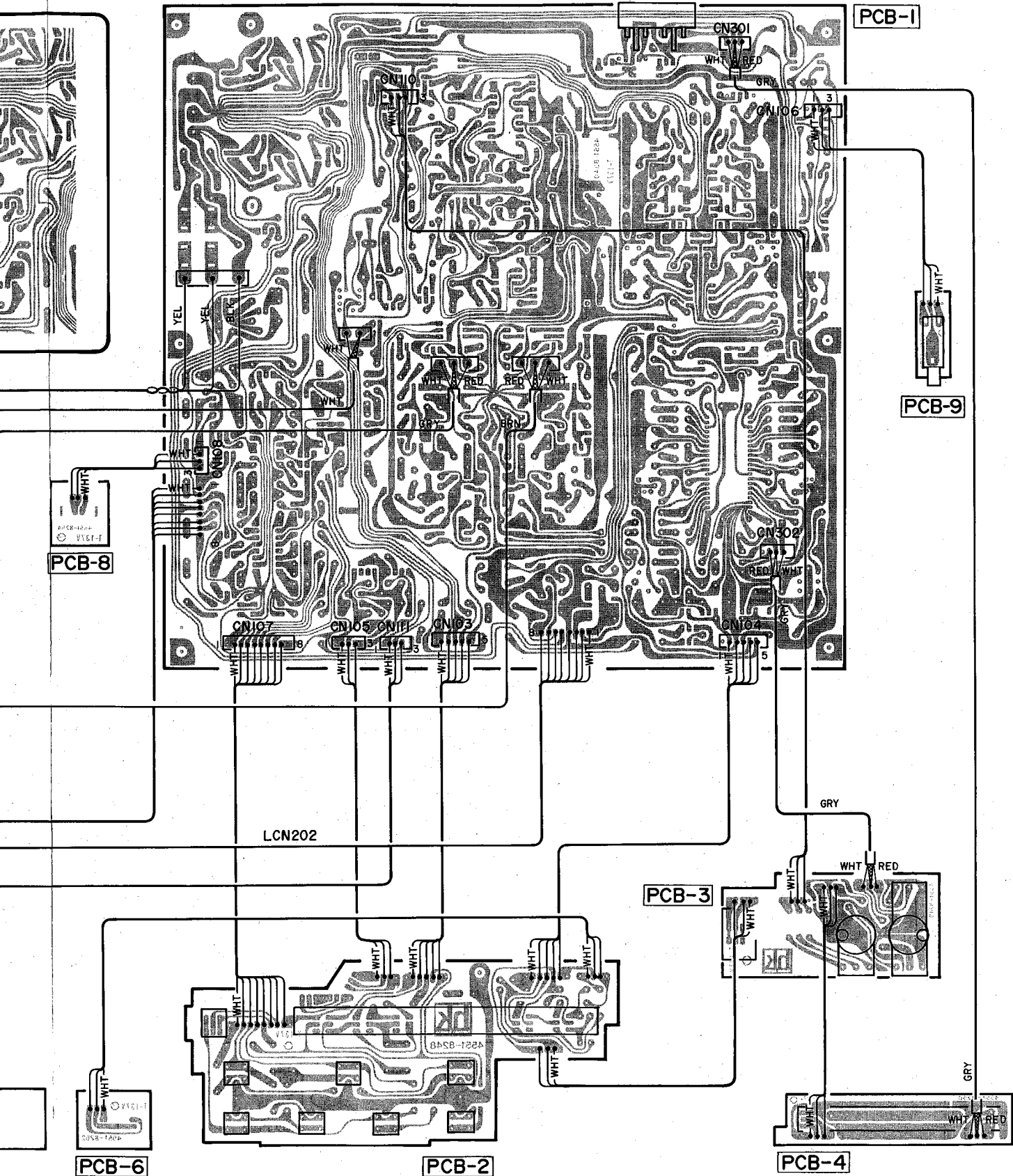

PCB-1

PCB-9

PCB-8

LCN202

PCB-3

PCB-6

PCB-2

PCB-4

SCHEMATIC DIAGRAM (1)

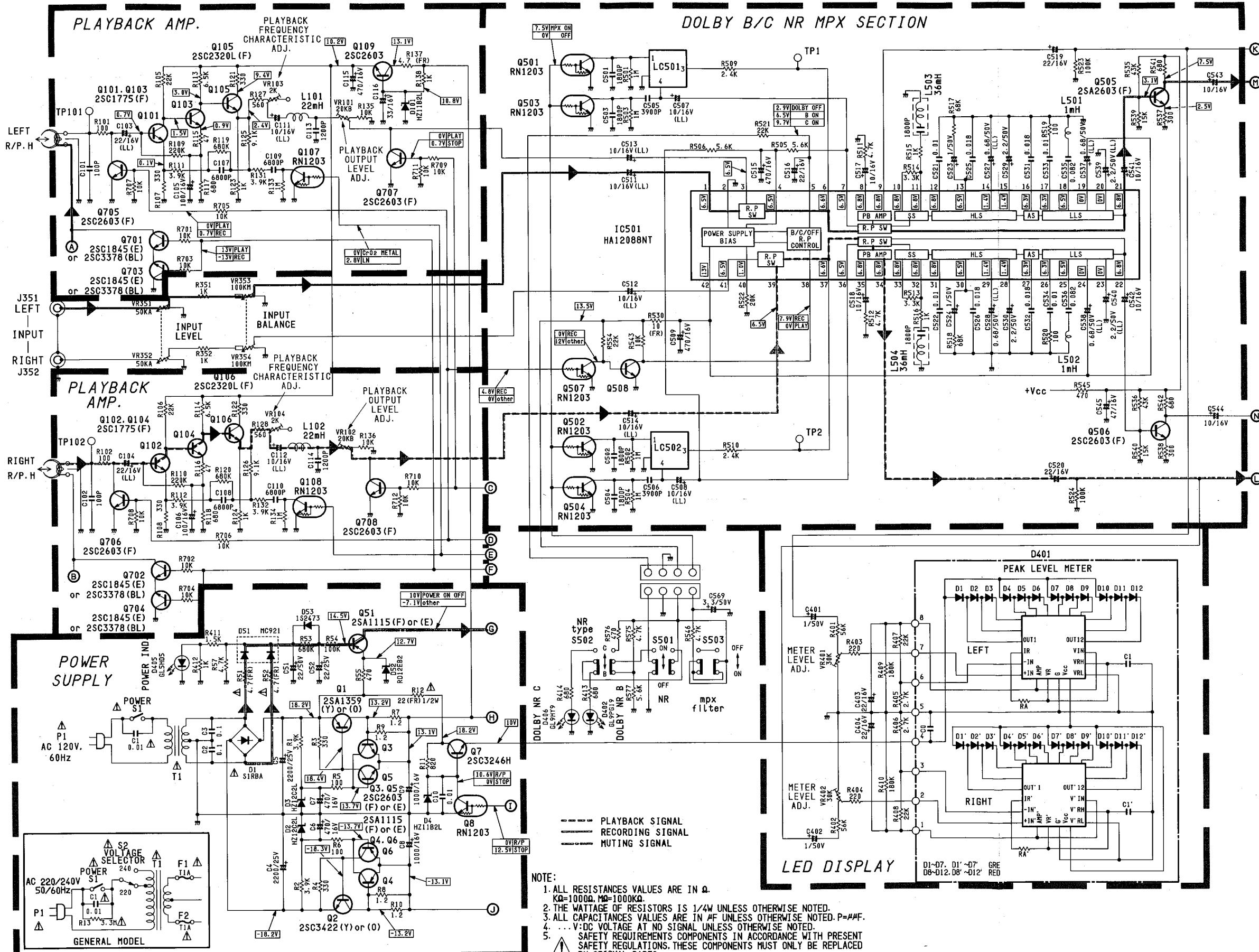

- NOTE:
1. ALL RESISTANCE VALUES ARE IN  $\Omega$ .  
K $\Omega$ =1000, M $\Omega$ =1000K.
  2. THE WATTAGE OF RESISTORS IS 1/4W UNLESS OTHERWISE NOTED.
  3. ALL CAPACITANCE VALUES ARE IN  $\mu$ F UNLESS OTHERWISE NOTED. P= $\mu$ F.
  4. ...V:DC VOLTAGE AT NO SIGNAL UNLESS OTHERWISE NOTED.
  5. SAFETY REQUIREMENTS COMPONENTS IN ACCORDANCE WITH PRESENT SAFETY REGULATIONS. THESE COMPONENTS MUST ONLY BE REPLACED BY ORIGINAL PARTS.

# SCHEMATIC DIAGRAM (1)

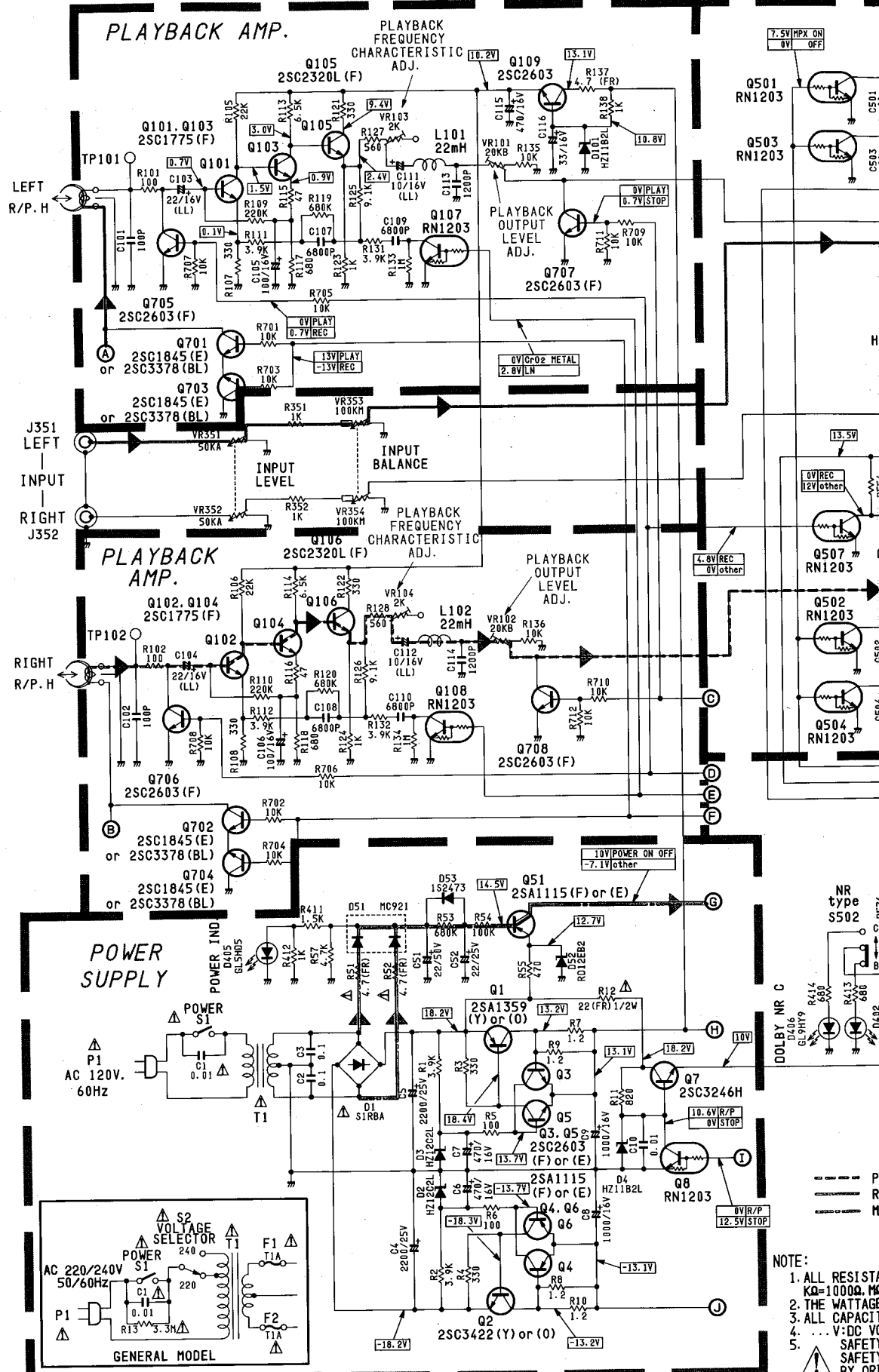



### DOLBY B/C NR MPX SECTION

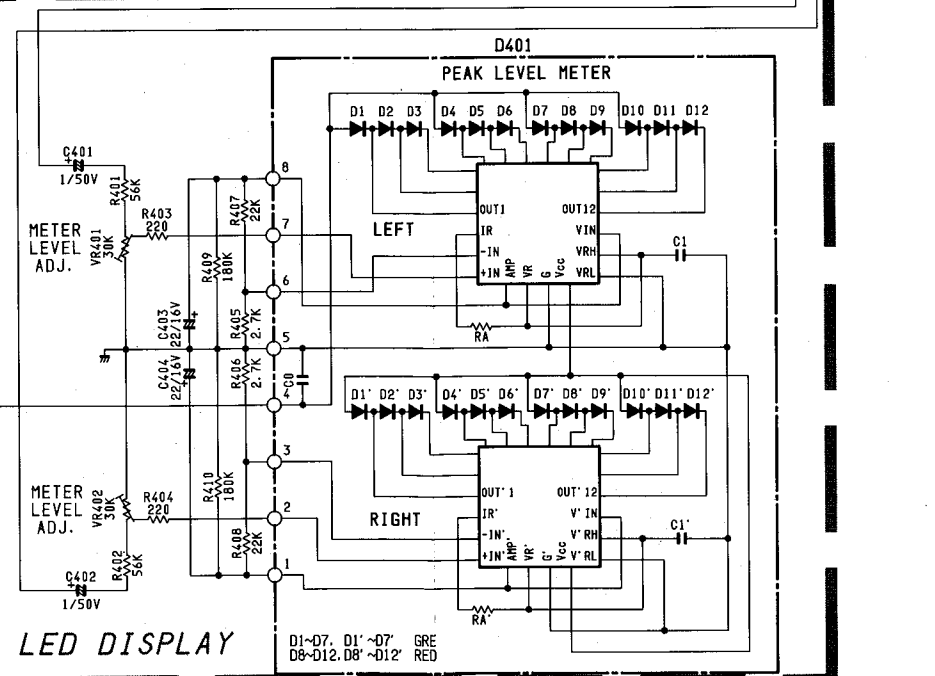
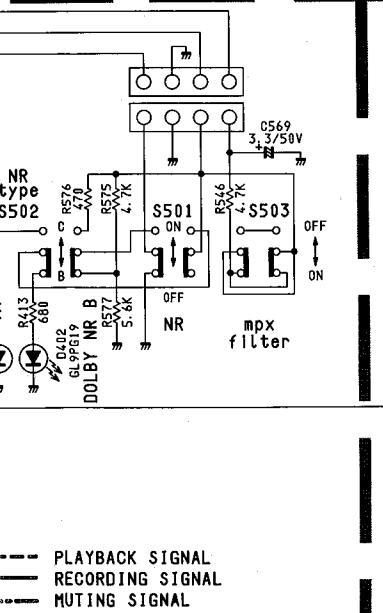
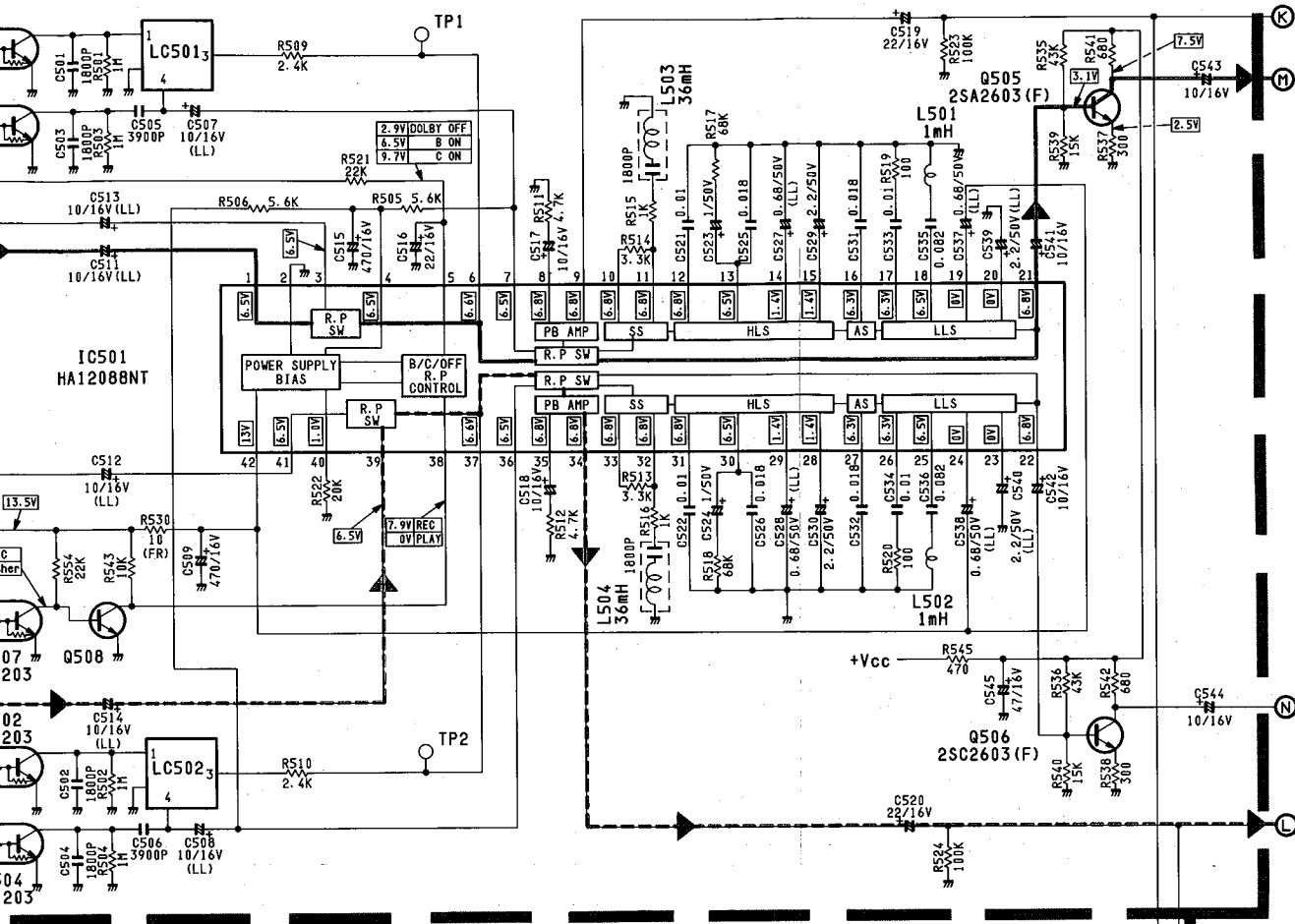

RESISTANCES VALUES ARE IN  $\Omega$ .  
 0000, M $\Omega$ =1000K $\Omega$ .  
 WATTAGE OF RESISTORS IS 1/4W UNLESS OTHERWISE NOTED.  
 CAPACITANCES VALUES ARE IN  $\mu$ F UNLESS OTHERWISE NOTED. P= $\mu$ MF.  
 V=DC VOLTAGE AT NO SIGNAL UNLESS OTHERWISE NOTED.  
 SAFETY REQUIREMENTS COMPONENTS IN ACCORDANCE WITH PRESENT  
 SAFETY REGULATIONS. THESE COMPONENTS MUST ONLY BE REPLACED  
 BY ORIGINAL PARTS.

**SCHEMATIC DIAGRAM (2)**

**LOGIC CONTROL BLOCK**

**HEADPHONE AMP.**

**BIAS/EQUALIZATION**

**RECORDING AMP.**

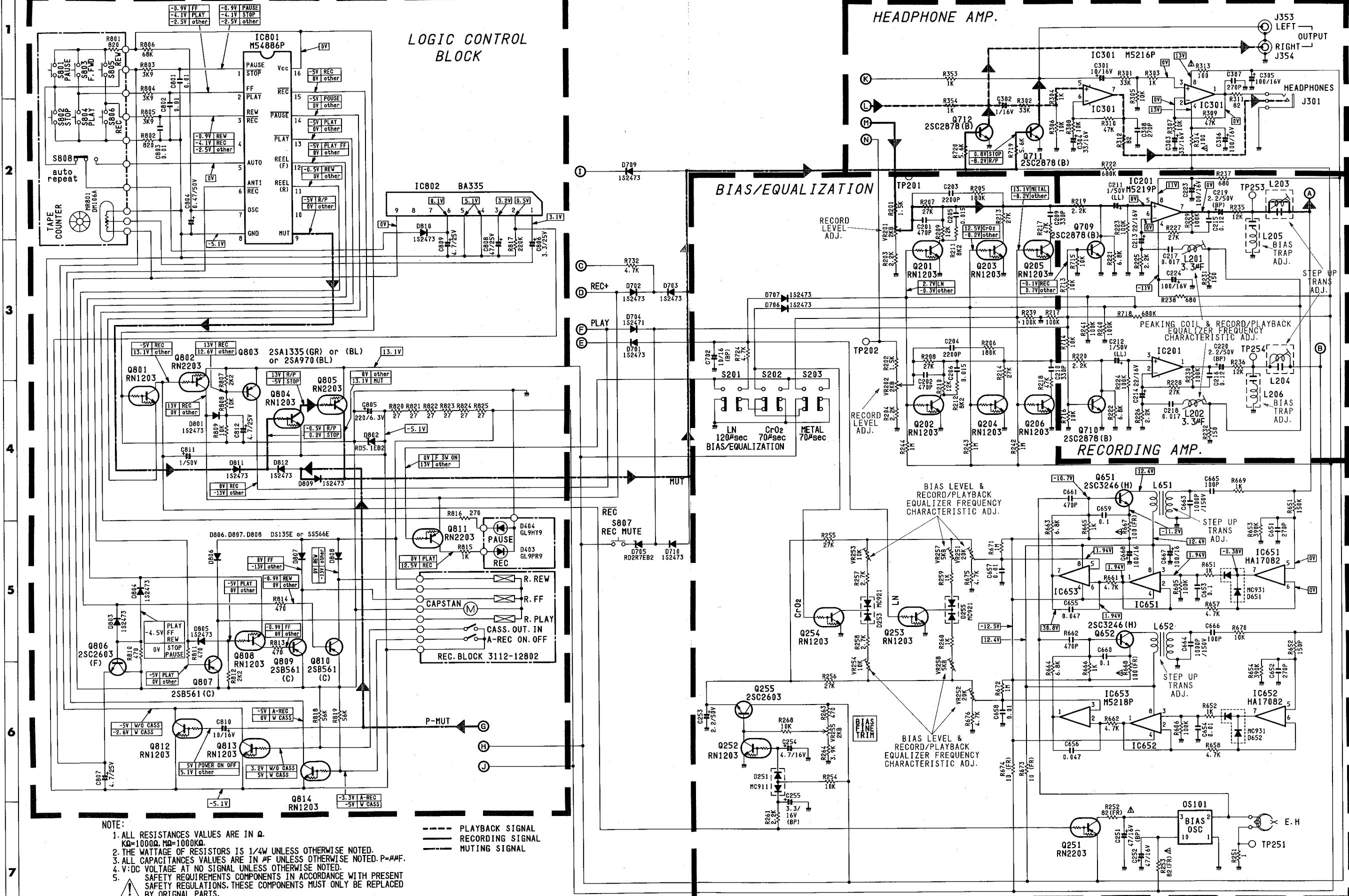

**NOTE:**

1. ALL RESISTANCE VALUES ARE IN  $\Omega$ .  
K $\Omega$ =1000 $\Omega$ , M $\Omega$ =1000K $\Omega$ .
2. THE WATTAGE OF RESISTORS IS 1/4W UNLESS OTHERWISE NOTED.
3. ALL CAPACITANCE VALUES ARE IN  $\mu$ F UNLESS OTHERWISE NOTED. P=#PF.
4. V-DC VOLTAGE AT NO SIGNAL UNLESS OTHERWISE NOTED.
5. SAFETY REQUIREMENTS COMPONENTS IN ACCORDANCE WITH PRESENT SAFETY REGULATIONS. THESE COMPONENTS MUST ONLY BE REPLACED BY ORIGINAL PARTS.

--- PLAYBACK SIGNAL  
 --- RECORDING SIGNAL  
 --- MUTING SIGNAL



**SCHEMATIC DIAGRAM (2)**

**LOGIC CONTROL BLOCK**

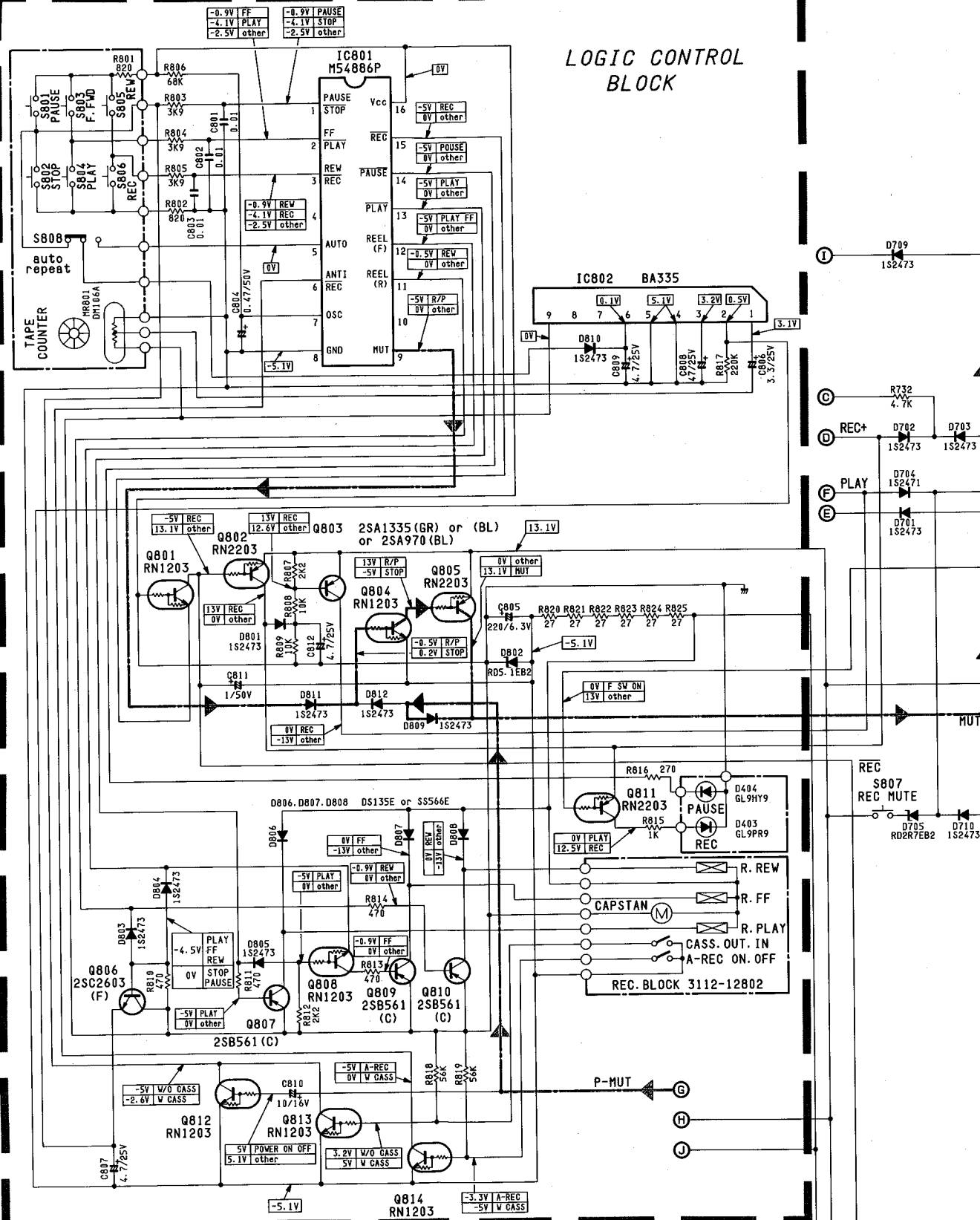

**NOTE:**

1. ALL RESISTANCES VALUES ARE IN  $\Omega$ .  
K $\Omega$ =1000 $\Omega$ , M $\Omega$ =1000K $\Omega$ .
2. THE WATTAGE OF RESISTORS IS 1/4W UNLESS OTHERWISE NOTED.
3. ALL CAPACITANCES VALUES ARE IN  $\mu$ F UNLESS OTHERWISE NOTED. P=# $\mu$ F.
4. V:DC VOLTAGE AT NO SIGNAL UNLESS OTHERWISE NOTED.
5. SAFETY REQUIREMENTS COMPONENTS IN ACCORDANCE WITH PRESENT SAFETY REGULATIONS. THESE COMPONENTS MUST ONLY BE REPLACED BY ORIGINAL PARTS.

- PLAYBACK SIGNAL
- RECORDING SIGNAL
- /——— MUTING SIGNAL

### HEADPHONE AMP.

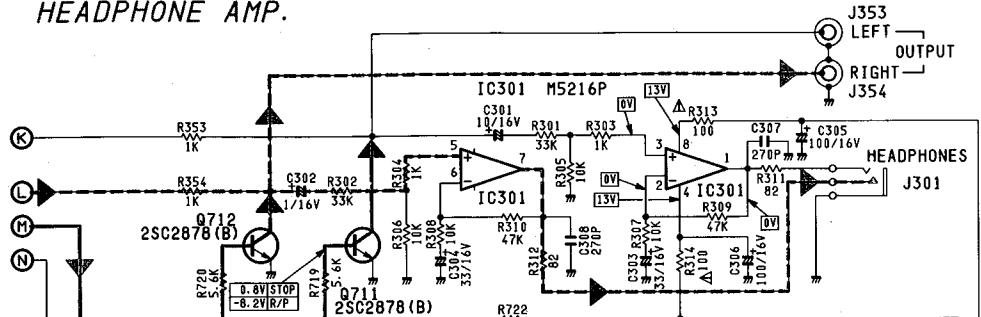

### BIAS/EQUALIZATION

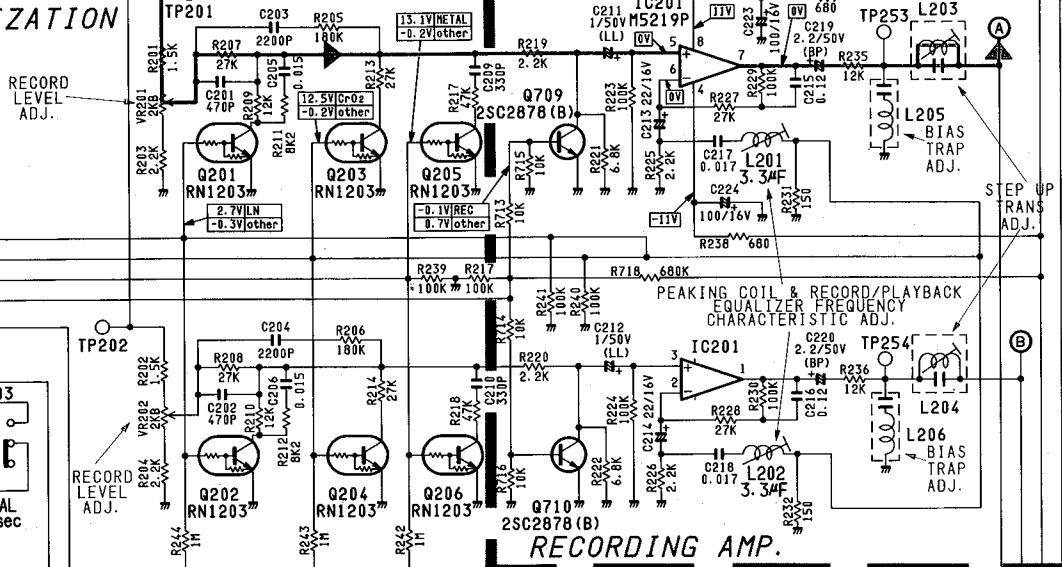

### RECORDING AMP.

